



Boggabri Coal Operations Pty Ltd
Site Water Balance
May 2017

Revision Control Chart

Revision	Date	Prepared by	Reviewed by	Approved by
0	27/04/2012	L Doeleman	L Gleeson, T Swanson	J Rennick
1	14/09/2012	L Doeleman	B Bird	J Green
2	19/07/2013	N Harcombe, A Hedjripour	S Trott, V O'Keefe	C Dingle
3	9/10/2013	N Harcombe, A Hedjripour	S Trott, V O'Keefe	C Dingle
4	18/11/2013	N Harcombe	S Trott	J Green
5	12/02/2014	K Agllias	S Trott	J Green
6	4/06/2015	L Doeleman	N Geale	J Green
7	10/09/2015	L Doeleman	N Geale	J Green
8	18/05/2017	T Tinkler, A Wyatt	H Russell	P Forbes

Contents

	Page Number
1. Introduction	5
1.1 Application of the SWB	6
1.2 Related water management documents	6
1.3 Consultation	7
1.4 Conditions of the Project Approval.....	7
1.5 Environment Protection Licence	7
2. Existing environment	9
2.1 Catchment description	9
2.2 Climate data	9
2.3 Design rainfall data	12
2.3.1 Intensity-frequency-duration rainfall data	12
2.3.2 Five day rainfall depths	12
2.4 Rainfall-runoff.....	13
2.4.1 AWBM rainfall-runoff model	13
3. Surface water management system.....	14
3.1 Design objectives	14
3.1.1 Clean water management system	14
3.1.2 Dirty water management system	15
3.1.3 Contaminated water management system	15
3.2 Water source prioritisation strategy	16
3.3 Design criteria	16
3.3.1 Dirty water sediment dams	16
3.3.2 Contaminated water dams	17
3.3.3 Clean water dams	18
3.3.4 Diversion drains	18
3.4 Existing water management system	18
3.5 2018 water management system	19
3.6 2022 water management system	20
3.7 2033 water management system	20
4. Site water balance model methodology.....	22
4.1 Modelling approach.....	22
4.2 Numerical implementation.....	23
4.3 Modelling assumptions.....	23
4.4 Site data	25
4.4.1 Storages	25
4.4.2 Catchments	26

4.4.3	Operating rules	27
4.5	Water sources	29
4.5.1	Rainfall and runoff	29
4.5.2	Groundwater inflows to mining void	30
4.5.3	Imported water	30
4.6	Water demands	33
4.6.1	Dust suppression	34
4.6.2	Coal handling and preparation plant	35
4.6.3	MIA and potable water	36
4.7	Other losses	36
4.7.1	Evaporation	36
4.7.2	Seepage from dams	36
4.7.3	Off-site releases	36
5.	Site water balance model validation	38
5.1	Data and assumptions	38
5.2	Runoff model calibration	38
5.3	Validation.....	40
6.	Site water balance model results	45
6.1	Overall site water balance	45
6.2	Imported water requirements	46
6.3	Contaminated water storage and pit availability	47
7.	Water efficiency initiatives.....	50
8.	Improvement and reporting	52
8.1	Annual Improvement Program	52
8.2	Validation Program.....	52
8.3	Annual Review	52
9.	Review and revision	53
9.1	Review.....	53
10.	References.....	54

List of tables

Table 1-1	Related water management documents	6
Table 1-2	Project conditions of approval – Planning and Assessment Commission of NSW	8
Table 2-1	Annual rainfall and evaporation statistics for Boggabri from 1889 to 2015 (Data Drill)	11
Table 2-2	IFD data for Boggabri Coal Mine site	12
Table 2-3	5-day rainfall depths for Boggabri Coal Mine site	12
Table 2-4	AWBM parameters	13
Table 4-1	Storages	25
Table 4-2	Catchment areas	26
Table 4-3	Operating rules	27
Table 4-4	Assumed operating volumes	29
Table 4-5	Summary of groundwater WALs currently held by BCOPL	31
Table 4-6	BCOPL water access licences for Lower Namoi Regulated River Water Source	32
Table 4-7	Haul road dust suppression demand estimates (average)	34
Table 4-8	CHPP demand estimates	36
Table 5-1	Validation data and assumptions	38
Table 5-2	Adopted AWBM parameter values	39
Table 5-3	Validation of annual totals	44
Table 6-1	Median site water balance for each of the snapshot years	45
Table 6-2	Annual totals of imported water requirements	46

List of figures

Figure 1.1	Document hierarchy	7
Figure 2.1	Annual rainfall for Boggabri from 1889 to 2015 (Data Drill)	10
Figure 2.2	Annual lake evaporation for Boggabri from 1889 to 2015 (Data Drill)	10
Figure 2.3	Average daily lake evaporation for Boggabri from 1889 to 2015 (Data Drill)	11
Figure 2.4	Schematic layout of the AWBM rainfall-runoff model	13
Figure 4.1	Interpolation of snapshot catchment areas and staging assumptions	24
Figure 4.2	Estimated groundwater inflows to mining void	30
Figure 4.3	Assumed borefield extraction rate varying with 4 year average rainfall	33
Figure 4.4	Observed water usage for dust suppression of haul roads	35
Figure 5-1	Calibration result - River extraction (observed minus modelled)	39
Figure 5-2	Observed and modelled total mining water storage volume	40
Figure 5-3	Observed and modelled MW2 water storage volume	41
Figure 5-4	Observed and modelled MW3 water storage volume	41
Figure 5-5	Observed and modelled SD10 storage volume	42
Figure 5-6	Observed and modelled Strip #9 water storage volume	42
Figure 5-7	Modelled monthly usage and supply	43
Figure 6.1	Simulated time series of annual water imported to site	46
Figure 6.2	Simulated time series of water stored in-pit sumps	48
Figure 6.4	Simulated time series of water stored in MW2 / MW5	48
Figure 6.5	Simulated time series of water stored in MW3	49

List of appendices

Appendix A	Summary of methodologies
Appendix B	Water management system plans and schematics
Appendix C	Summary of storages and discharge points
Appendix D	Water management system stage-storage relationships

Abbreviations

Abbreviation	Term
AEMR	Annual Environmental Management Report
ARI	Average Recurrence Interval
AWBM	Australian Water Balance Model
AWD	Available Water Determinations
BCM	Boggabri Coal Mine
BCOPL	Boggabri Coal Operations Pty Limited
BOM	Bureau of Meteorology
BTM Complex	Boggabri-Tarrawonga-Maules Creek Complex
CCC	Community Consultative Committee
CD	Clean Water Highwall Dam
CHPP	Coal Handling and Preparation Plant
DP&E	NSW Department of Planning and Environment
EA	Environmental Assessment
EC	Electrical Conductivity
EPA	Environment Protection Authority
EP&A Act	<i>Environmental Planning and Assessment Act, 1979</i>
EPL	Environment Protection Licence
GWMP	Groundwater Management Plan
HD	Highwall Dam
IFD	Intensity-Frequency-Duration
MCCM	Maules Creek Coal Mine
MIA	Mine Infrastructure Area
ML	Megalitres
Mtpa	Million Tonnes Per Annum
MWD	Mine water dam
NLLS	North West Local Lands Services (formerly Namoi Catchment Management Authority)
DPI Water	Department of Primary Industry – Water (formerly NSW Office of Water)
PAC	NSW Planning Assessment Commission
ROM	Run of Mine
SD	Sediment dam
SWB	Site Water Balance
SWMP	Surface Water Management Plan
TCM	Tarrawonga Coal Mine
TCPL	Tarrawonga Coal Pty Ltd
WAL	Water Access Licence
WMP	Water Management Plan
WSP	Water Sharing Plan

1. Introduction

This Site Water Balance (SWB) has been developed for Boggabri Coal Mine (BCM) which is managed by Boggabri Coal Operations Pty Ltd (BCOPL). BCOPL is owned by Idemitsu Australia Resources Pty Limited (80%), Chugoku Electric Power Australia Resources Pty Ltd (10%) and NS Boggabri Pty Limited (10%). BCM is located 15 km north-east of the township of Boggabri in north-western New South Wales, as shown in Figure B-1.

BCM is an open cut coal mine that has been operating since 2006. Truck and excavator operations are used to mine a run-of-mine (ROM) coal which is crushed and screened to produce a thermal coal product or washed in the Coal Handling Preparation Plant (CHPP) to produce Coking or Pulverised Coal Injected product. Product coal is loaded onto trains via a train loading facility at the mine site and transported by rail to the Port of Newcastle for overseas consumption.

BCM is managed by BCOPL, who also operate the Coal Handling and Preparation Plant (CHPP). BCOPL engages a Mining Operator to undertake open cut mining activities. All contractors working at the BCM are required to operate in compliance with the Water Management Plan (WMP), of which this Site Water Balance (SWB) forms a component.

Project Approval number 09_0182 for the Boggabri Coal Project, granted by the NSW Planning Assessment Commission (PAC) under Part 3A of the *Environmental Planning and Assessment Act* 1979 (EP&A Act) on 18 July 2011, as modified from time to time, (Project Approval) allows BCOPL to extend its mining operations for a further 21 years, and increase its production rate to 8.6 Mtpa of ROM coal from a total resource of 145 Mt.

In 2015, BCOPL lodged an application under Section 75W of the EP&A Act 1997 to modify PA09_0182 (MOD 5). The modification was supported by an Environmental Assessment (Parsons Brinckerhoff, 2015) for the conversion of existing test bores to operational production bores for the supply water to BCM and the installation of ancillary infrastructure on adjoining properties. The application was determined by the NSW Department of Planning and Infrastructure, Executive Director under delegation by the Minister for Planning and was approved on 30 August 2016

Schedule 3, Condition 38 (a) of the state Project Approval requires the preparation of a SWB. This SWB has been prepared in fulfilment of these requirements. The specific requirements of the SWB are listed in Table 1.3.

Conditions of approval under the Environmental Protection and Biodiversity Conservation Act 1999 (EPBC Act) were granted by the then Commonwealth Department of Sustainability, Environment, Water, Population and Communities (now Department of Environment and Energy (DoEE)) on 11 February 2013 (EPBC Approval). The EPBC Approval conditions do not relate specifically to the SWB, but rather to the Surface Water Management Plan (SWMP). The SWB forms part of the SWMP.

The SWB considers the current Life-of-Mine planning and information available to define components of the SWB. To ensure clarity throughout the SWB, reference is made to two distinct mine plans for which demand, usage and storage characteristics are based, specifically the:

1. Revised Draft Mining Operations Plan (MOP): lodged with the NSW Division of Resources and Energy (DRE) in January 2017. The MOP spans a period between 2015 and 2019. Mine plan snapshots and water management systems relevant to mine years existing and 2018, are aligned with the MOP.
2. Environmental Assessment (EA) Mine Plan: lodged in 2009 and conditionally approved by the NSW Minister for Planning and Infrastructure (now Minister for Planning) in July 2012. The EA mine plan spans a 21 year period between 2013 and 2034. Mine plan snapshots and water management system for years 2022 and 2033 in this SWMP are based on the EA mine plan.

1.1 Application of the SWB

This SWB applies to all employees and contractors at the Boggabri Coal Mine and covers all areas within the 'Project Boundary' described in Appendix 1 of the Project Approval and shown in Figure B-1.

1.2 Related water management documents

This SWB report has been prepared as an integral part of, and should be read in conjunction with the documents listed in Table 1-1. The WMP document hierarchy is shown in Figure 1.1.

Table 1-1 Related water management documents

Document	Description
Boggabri Tarrawonga Maules Creek (BTM) Complex Water Management Strategy	Regional strategy prepared in consultation with Tarrawonga Coal Pty Ltd (TCPL) and Maules Creek Coal Project (MCC)
Water Management Plan	Overarching document setting out water management framework, statutory requirements and procedural requirements
Surface Water Management Plan	Surface water baseline data, performance criteria, monitoring program, response plan, water management system description, erosion and sediment controls
Groundwater Management Plan	Groundwater baseline data, performance criteria, monitoring program, response plan, groundwater model validation program
Site Water Balance report	Mine water balance modelling methodology, assumptions and results, mine water management system operating philosophy

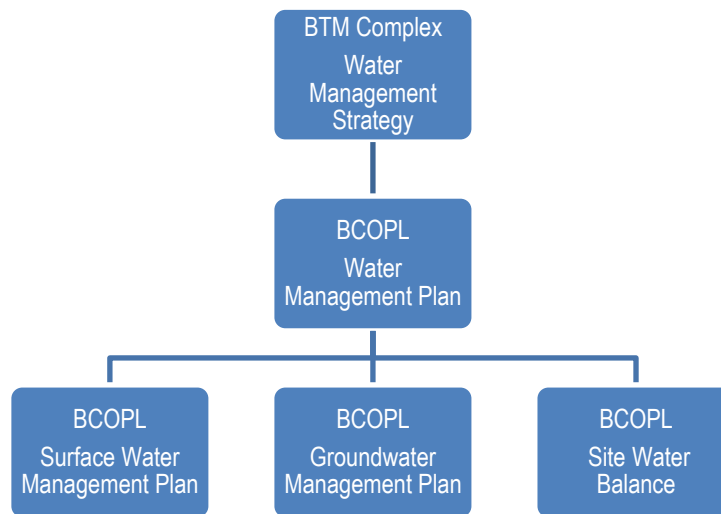

Figure 1.1 Document hierarchy

1.3 Consultation

Previous versions of this SWB have been prepared in consultation with representatives from the NSW Environment Protection Agency (EPA), NSW Department of Primary Industry – Water (DPI Water) (formerly Office of Water), North West Local Land Services (NLLS) (formerly Namoi Catchment Management Authority and the Community Consultative Committee (CCC).

The SWB has been prepared by suitably qualified persons approved by DP&E to undertake this work. The SWB has been reviewed by DP&E and comments have been addressed.

Previous versions of the SWB have been submitted to regulators (EPA and DPI Water), NLLS and the CCC, and have been updated to incorporate feedback from regulators and the CCC.

1.4 Conditions of the Project Approval

The Project Approval conditions outlining the requirements for the SWB are provided in Section 3.3 of the WMP and summarised in Table 1-2.

1.5 Environment Protection Licence

The existing conditions described in this SWB reflect the conditions set out in the current EPL (12407, as at the date of the SWB). Condition L1.1 requires compliance with Section 120 of the *Protection of the Environment Operations Act 1997*. EPL discharge points will be reviewed and updated in consultation with the EPA. Discharge criteria are outlined in the Surface Water Management Plan (SWMP).

Table 1-2 Project conditions of approval – Planning and Assessment Commission of NSW

Applicable Condition	Requirement	SWB Reference
Schedule 3, Condition 38(a)	<p>The Proponent shall prepare and implement a Water Management Plan for the project to the satisfaction of the Secretary. This plan must be prepared in consultation with OEHL, DPIW, North Water Local Land Service and the CCC, by suitably qualified and experienced person/s whose appointment has been approved by the Secretary, and be submitted to the Secretary for approval within 6 months of the date of this approval [which shall include]:</p> <ul style="list-style-type: none"> ▪ a Site Water Balance, that: <ul style="list-style-type: none"> ▪ includes details of: <ul style="list-style-type: none"> ▶ sources and security of water supply, including contingency for future reporting periods; ▶ prioritisation strategy for water sources; ▶ water use on site; ▶ water management on site; ▶ any off-site water discharges; ▶ reporting procedures, including the preparation of a site water balance for each calendar year; ▶ a program to validate the surface water model, including monitoring discharge volumes from the site and comparison of monitoring results with modelled predictions; ▶ methodologies used in the preparation of the site water balance, including provision of data sources, measurement type (direct sample / mass balance / engineer calculations / factors) and formulas used for all inflows, processes and outflows; and ▪ is supported by an annual improvement program to identify and address deficiencies and improvements within monitoring, measurement and calculation methods; and ▪ includes an action plan and schedule to implement annual water efficiency initiatives and the recommendations in the Advisian peer review report titled "Peer Review of Site Water Balance Use Aspects of Boggabri Coal MOD 5 Project, 22 July 2016" as set out in Appendix 6A; and ▪ describes the measures that would be implemented to minimise clean water use on site 	<p>This SWB forms part of the WMP. Suitably qualified and approved persons have prepared the plan in accordance with this requirement.</p> <hr/> <p>Refer to Section 4 and Section 6</p> <hr/> <p>Refer to Section 4.5 and Table 6-1</p> <hr/> <p>Refer to Section 3.2</p> <hr/> <p>Refer to Section 4.6</p> <hr/> <p>Refer to Section 3</p> <hr/> <p>Refer to Section 4.7.3 and Table 6-1</p> <hr/> <p>Refer to Section 8.3</p> <hr/> <p>Refer to Section 8.2</p> <hr/> <p>Refer to Section 4 and Appendix A</p> <hr/> <p>Refer to Section 8.1</p> <hr/> <p>Refer to Section 7</p> <hr/> <p>Refer to Section 3.1.1</p>

2. Existing environment

2.1 Catchment description

The Boggabri Coal Mine and Mine Infrastructure Area (MIA) are contained within the catchment of an unnamed ephemeral drainage line locally referred to as Nagero Creek. Nagero Creek is an ephemeral stream that is a tributary of the Namoi River.

The Nagero Creek catchment is described in the Surface Water Management Plan (SWMP).

2.2 Climate data

Daily rainfall and evaporation data for the site for the 126 year period between 1889 and 2016 was obtained from the Bureau of Meteorology (BOM) Data Drill service. The Data Drill accesses grids of data derived by interpolating the BOM's station records, as described in Jeffrey, Carter, Moodie & Beswick (2001). The data in the Data Drill are all synthetic; no original meteorological station data are left in the calculated grid fields. However, the Data Drill does have the advantage of being available for any set of coordinates in Australia (BOM, 2006).

The Data Drill is considered superior to individual BOM station records and site meteorological station data for long-term water balance modelling purposes because it draws on a greater dataset, both spatially and in time. The Data Drill is also considered superior for modelling purposes as it does not contain gaps.

Plots of Data Drill sourced annual rainfall and annual lake evaporation for the 126 year period between 1889 and 2015 are provided in Figure 2.1 and Figure 2.2 respectively. A plot of Data Drill sourced average daily lake evaporation for each month of the year is provided in Figure 2.3. Summary statistics of Data Drill sourced annual rainfall and evaporation are provided in Table 2-1.

Daily evaporation estimates for open water bodies were obtained from the Data Drill based on Morton's Lake evaporation data. SILO calculates Morton's Lake evaporation using Morton's formula for shallow lakes as described in Morton (1983). Evapotranspiration estimates were based on Data Drill sourced daily FAO56 short crop as described in Smith (1998).

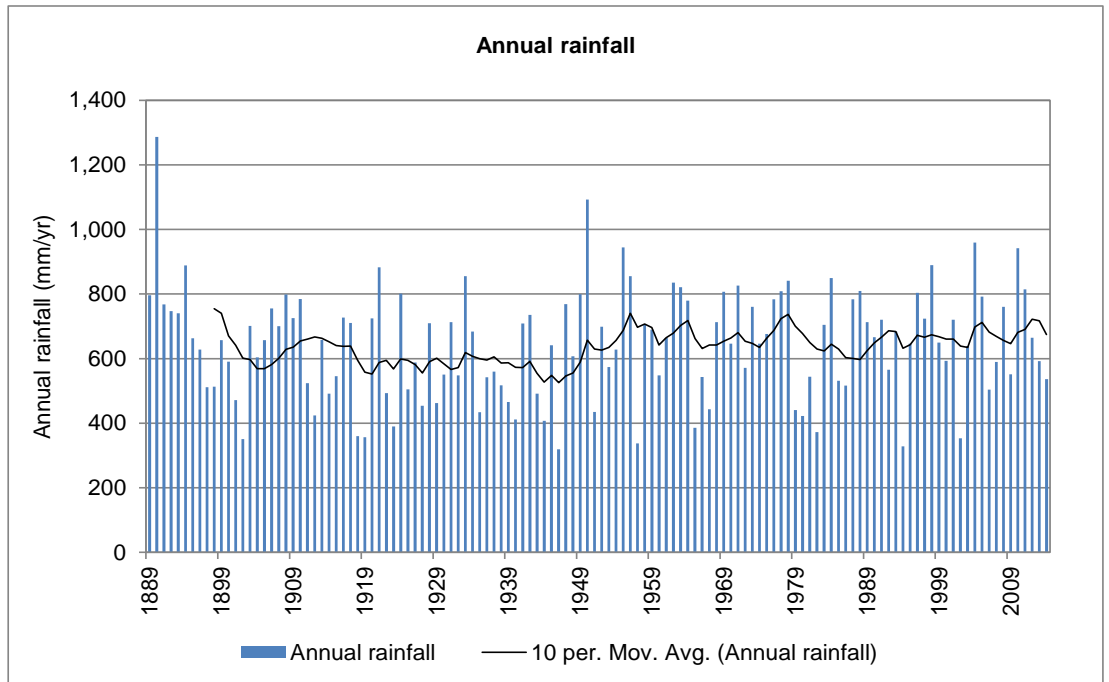

Figure 2.1 Annual rainfall for Boggabri from 1889 to 2015 (Data Drill)

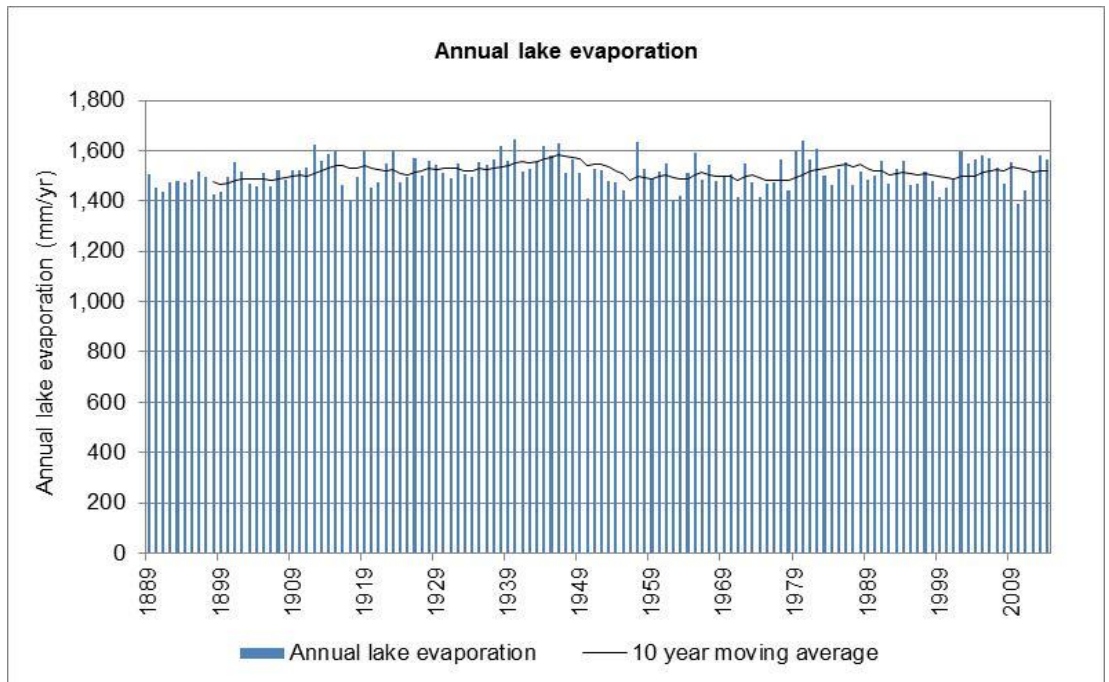

Figure 2.2 Annual lake evaporation for Boggabri from 1889 to 2015 (Data Drill)

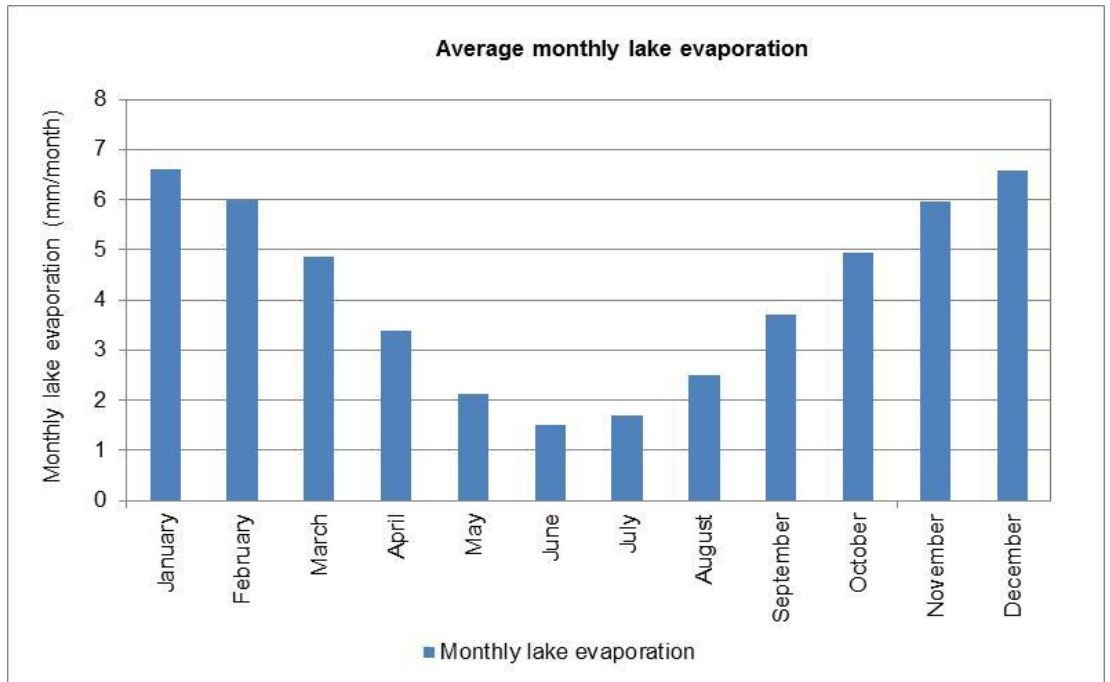

Figure 2.3 Average daily lake evaporation for Boggabri from 1889 to 2015 (Data Drill)

Table 2-1 Annual rainfall and evaporation statistics for Boggabri from 1889 to 2015 (Data Drill)

Percentile	Annual rainfall (mm/yr)	Annual potential evapotranspiration (mm/yr) ¹	Annual lake evaporation (mm/yr) ²
minimum	319	1,253	1,389
5th percentile	363	1,310	1,414
10th percentile	423	1,339	1,441
50th percentile	658	1,418	1,511
90th percentile	831	1,536	1,594
95th percentile	887	1,574	1,617
maximum	1,287	1,634	1,643

¹ Potential evapotranspiration calculated using the Penman-Monteith formula given in Irrigation and Drainage paper No. 56 Food and Agriculture Organization of the United Nations (Smith, 1998).

² Lake evaporation calculated using Morton formula for shallow lakes given in the Journal of Hydrology, Volume 66, page 1-77, paper (Morton, 1983).

Daily rainfall data has been recorded at the Boggabri Coal Mine meteorological station since July 2006. The site meteorological station data has been used to verify the water balance model against site monitoring results recorded for the period from 2013 to 2015 (discussed in Section 5).

2.3 Design rainfall data

2.3.1 Intensity-frequency-duration rainfall data

Design intensity-frequency-duration (IFD) rainfall data for the mine site area was obtained from the BOM website, and is provided in Table 2-2. This information is typically used in the sizing of contaminated water dams (i.e. 100 year Average Recurrence Interval (ARI) 72 hour volume is typically used to achieve the no spills principle).

Table 2-2 IFD data for Boggabri Coal Mine site

Duration	Rainfall intensity (mm/hr)						
	1 year ARI	2 year ARI	5 year ARI	10 year ARI	20 year ARI	50 year ARI	100 year ARI
5 mins	70.7	92.9	123	144	171	209	240
10 mins	53.6	70.4	93.5	109	129	158	181
20 mins	39.3	51.6	68.3	79.3	93.9	115	131
30 mins	31.9	41.8	55.3	64.1	75.9	92.6	106
1 hr	21.1	27.7	36.6	42.4	50.2	61.2	70.2
2 hrs	13.2	17.3	22.9	26.6	31.5	38.4	44
3 hrs	9.84	12.9	17.1	19.9	23.6	28.8	33
6 hrs	5.91	7.77	10.3	12	14.3	17.4	20
12 hrs	3.58	4.71	6.29	7.34	8.73	10.7	12.3
24 hrs	2.19	2.9	3.9	4.58	5.47	6.73	7.77
48 hrs	1.33	1.76	2.39	2.82	3.39	4.20	4.86
72 hrs	0.95	1.26	1.73	2.04	2.46	3.06	3.55

2.3.2 Five day rainfall depths

Five day rainfall depths for the mine site have been estimated based on the values provided for Gunnedah in the guidelines *Managing Urban Stormwater – Soils and Construction – Volume 1* (Landcom, 2004), and are provided in Table 2-3. These depths are typically used in the sizing of sediment dams. The guidelines recommend designing to the 90th percentile storm event for a sediment dam with duration of disturbance greater than three years and with a standard receiving environment.

Table 2-3 5-day rainfall depths for Boggabri Coal Mine site

Percentile	5-day rainfall depth (mm)
75 th percentile	20.0
80 th percentile	24.1
85 th percentile	30.2
90 th percentile	38.4
95 th percentile	53.0

2.4 Rainfall-runoff

The volume of surface water runoff in the mine site catchment has been estimated using the Australian Water Balance Model (AWBM) rainfall-runoff model that has been incorporated into the site water balance model.

2.4.1 AWBM rainfall-runoff model

The AWBM (Boughton, 1993) was used to estimate catchment runoff from various land uses in the catchment area of the site. The catchment area reporting to each surface water storages at the site was distributed spatially to different land use categories. The land use categories considered were undisturbed, rehabilitated spoil, industrial (hardstand and infrastructure areas), mining void (pit), active spoil and pre-strip.

The AWBM is a partial area saturation overland flow model. The use of the partial area saturation overland flow approach is simple, and provides a good representation of the physical processes occurring in most Australian catchments (Boughton, 1993). This is because daily infiltration capacity is rarely exceeded, and the major source of runoff is from saturated areas. A schematic layout of the AWBM is provided in Figure 2.4.

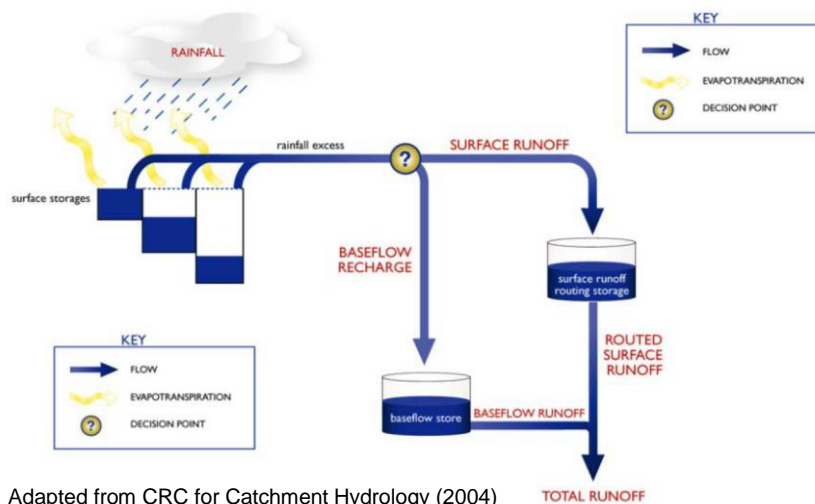

Adapted from CRC for Catchment Hydrology (2004)

Figure 2.4 Schematic layout of the AWBM rainfall-runoff model

To implement the AWBM in a given catchment, a set of nine parameters must be defined as summarised in Table 2-4. These parameters define the generalised model for a particular catchment. The model parameters were calibrated to produce the best match between the site observations and corresponding modelled variables. The calibration process and the adopted parameter values are described in Section 5.

Table 2-4 AWBM parameters

Parameter	Description
A1, A2, A3	Partial areas represented by surface storages
C1, C2, C3	Surface storage capacities
K_s	Daily surface flow recession constant
BFI	Baseflow index
K_{base}	Daily baseflow recession constant

3. Surface water management system

3.1 Design objectives

The key objectives of the water management system design for the Boggabri Coal Mine are to:

- segregate clean runoff, dirty runoff and contaminated water generated from rainfall events and mining operations where reasonable and feasible
- minimise the volume of contaminated mine water (surface runoff draining to pit) generated by the Project
- provide sufficient on-site storage to store contaminated water that could affect the quality of downstream watercourses
- where reasonable and feasible treat dirty runoff from un-rehabilitated overburden areas to settle coarse suspended solids
- where reasonable and feasible divert clean runoff to downstream creeks

The following definitions have been adopted for the various runoff types:

- **Clean runoff** is defined as runoff from catchments that is not disturbed by mining operations.
- **Dirty runoff** is defined as runoff from disturbed areas within the mine site and includes runoff from the spoil dumps, haul roads and parts of the MIA. This water contains high levels of suspended solids.
- **Contaminated runoff** is defined as runoff generated from coal stockpiles, the CHPP, parts of the MIA and the mining void, as well as groundwater inflows to the mining void. This water contains high levels of suspended solids and is mildly saline.

Water management system indicative layout plans for existing, 2018, 2022 and 2033 are provided in Figure B-2 to Figure B-5, Appendix B. Schematic diagrams showing the general connectivity between water sources, demands and storages for existing, 2018, 2022 and 2033 are also provided in Figure B-6 to Figure B-9, Appendix B. Note year 2022 corresponds to 'Year 10' from the EA, and year 2033 corresponds to 'Year 21' from the EA.

3.1.1 Clean water management system

The clean water management system will, where reasonable and feasible, divert clean water runoff from undisturbed catchments around the mine working area and into Nagero Creek. This minimises the clean catchment runoff entering the dirty and contaminated water systems and therefore minimise the clean water use on site.

In some instances, as the mine pit footprint changes, remnant undisturbed catchments that are unable to be feasibly diverted around the pit via clean water drains due to topographical limitations may remain. In these instances, where feasible, highwall dams

(HD) will be constructed upslope of the pit to intercept these flows and provide temporary storage, with subsequent controlled pump-out and discharge to a suitable receiving creek system at a downstream point.

In other locations it is not feasible to provide diversion drains or highwall dams due to the advancing topsoil stripping and stockpiling. In these circumstances clean water will be allowed to enter the active mining areas and the dirty water diversion system. BCOPL will be required to account for the additional captured water and hold adequate licences or harvestable rights.

3.1.2 Dirty water management system

Dirty water runoff will be captured in sediment dams to encourage the settling of suspended solids. Runoff from large storm events (i.e. typically exceeding the 90th percentile 5 day rainfall depth) will overtop sediment dams and discharge to Nagero Creek. Captured water will either be discharged to Nagero Creek (where the water quality meets EPL12407 requirements) or pumped to mine water dams (MWDs) for storage and reuse. This will depend on water quality and the SWB.

Water captured in sediment dams should be suitable for release following settling of suspended solids. However, as spoil dump runoff has the potential to have elevated acidity, salinity, dissolved metals and oils and greases, sediment dams will be provided with manually operated valves on the outlet pipes. Alternatively, sediment dams will be provided with a mobile pump out system only. This will minimise discharge to the creek if water quality is not suitable (and to allow for flocculation or other measures required to attain the approved discharge water quality criteria).

During 2013 and 2014, site catchment inflows (direct rainfall, catchment runoff and groundwater inflows into the mine void) exceeded site water demands. This resulted in an annual water surplus at the BCM. Sediment dam water were therefore discharged to Nagero Creek following settling under normal operating conditions in 2013 and 2014 to minimise the volume of water that accumulated onsite (when the EPL discharge criteria was met). Sediment dam water was only reused onsite in 2013 and 2014 when water quality was not suitable for discharge to the creek system.

Following the commissioning of the CHPP in 2015, the site demands increased and exceeded the average site catchment inflows. Therefore, the BCM moved to, and is predicted to remain in, an annual water deficit under most climatic conditions.

3.1.3 Contaminated water management system

Contaminated water will be stored in contaminated water dams, MWDs or the mining void and will not be discharged to Nagero Creek. The water management system will reuse as much contaminated water as possible onsite for dust suppression and coal washing (excluding a minimum imported water component required for potable and washdown demand). When the capacity of MWDs is reached surplus contaminated water will either be treated to meet the EPL water quality criteria for a controlled discharged or will be stored in the pit void.

3.2 Water source prioritisation strategy

Water required to satisfy the site demands will be sourced from onsite surface water storages and supplemented with imported water, in order of priority, from:

1. Surface water stored in water storages (consisting of contaminated water stored in mining water storages and pit void, and dirty water in sediment dams).
2. Imported water (consisting of groundwater from the Upper Namoi Zone 4 Groundwater Source via the borefield and river water from the Lower Namoi Regulated River Water Source via the pump station on the Namoi River).

On a day to day operational basis, imported water may be sourced while stored water is present onsite in order to meet operational demands. However, on average over the longer term, contaminated and dirty water will be used in preference to imported water.

The water quality of contaminated and dirty water make it unsuitable for some water demands in the CHPP and washdown facilities (refer to Section 4.6.3). Therefore, imported water will be used for the supply of water for use on site facilities (i.e. administration buildings and bathhouses) and for washdown facilities.

3.3 Design criteria

3.3.1 Dirty water sediment dams

Dirty water sediment dams have been sized based on the criteria recommended in the guidelines *Managing Urban Stormwater - Soils and Construction - Volume 2E Mines and Quarries* (DECCW, 2008) (The Blue Book).

The Blue Book guidelines recommend that Type F/D sediment basins be provided for catchments with fine or dispersible soils. These are 'wet basins', comprising a 'settling zone' for temporary treatment storage and a 'sediment zone' for storage of sediment.

The Blue Book guidelines recommend that the 'settling zone' be sized to capture the 90th percentile 5 day duration storm event, and the 'sediment zone' be sized at 50% of the 'settling zone' volume. This sizing is based on site disturbance duration of more than three years, and results in an average sediment dam overflow frequency of approximately two to four overflows per year. For sizing purposes, a runoff coefficient of 0.75 has been adopted for disturbed areas such as overburden emplacement areas and topsoil stockpiles. A runoff coefficient of 0.4 has been adopted for undisturbed areas. As sediment dams have been sized for a 5 day management period, the 'settling zone' should be drained or pumped out within 5 days following a rainfall event that results in runoff entering the sediment dam.

Sediment dams in the MIA are sized in accordance with "Blue Book" requirements. MIA sediment dams will not capture contaminated runoff. In particular, any contaminated water from the vehicle washdown bay in the MIA will be recirculated within the wash down bay system or drained to the CHPP contaminated water dams. A runoff coefficient of 0.85 has been adopted for disturbed areas in the upgraded MIA, which are expected to comprise mainly hardstand surfaces. A runoff coefficient of 0.75 was adopted for the existing MIA, which comprises a mix of hardstand surfaces and grassed surfaces.

Key design features of dirty water sediment dams are as follows:

- Configured as Type F/D basins as described in the Blue Book guidelines.
- 'Settling zone' for temporary treatment storage.
- 'Sediment zone' for sediment storage.
- Slotted riser and discharge pipe with valve arrangement to allow manual operation of pipe (alternatively a mobile pump-out system).
- Slotted riser and discharge pipe sized to drawdown 'settling zone' over three days.

Dirty water sediment dams are to be maintained in a drawn down state as much as practical, thus ensuring that sufficient capacity is available in the 'settling zone' to capture water from subsequent storm events. Water will only be stored in the 'settling zone' of dirty water sediment dams on a temporary basis (i.e. the nominated 5 day management period) following a rainfall event of sufficient depth to result in runoff entering the sediment dam. If water stored in the sediment dam is not suitable for discharge, or is to be reused onsite. The sediment dam water would need to be pumped to the much larger MWDs for long term storage and onsite reuse.

3.3.2 Contaminated water dams

3.3.2.1 Contaminated water dams

Contaminated water dams (also called coal contact dams) capture runoff from the coal stockpile pads in the CHPP. Water stored in contaminated water dams is reused onsite for dust suppression or CHPP process water, or pumped to MWDs for storage.

Contaminated water dams have been designed to store runoff from a 100 year ARI 72 hour duration design storm event, with a 20% allowance for sediment storage. A runoff coefficient of 0.85 has been adopted for disturbed areas in the CHPP, which are expected to comprise mainly hardstand surfaces. A runoff coefficient of 0.75 was adopted for the existing coal crushing and handling area which comprises a mix of hardstand surfaces and grassed surfaces.

Key design features of contaminated water dams are as follows:

- 'sediment zone' for storage of sediment.
- 'storm zone' for storage of the design storm storage.
- pump and pipeline system to draw down the 'settling zone' to the MWDs.

Contaminated water dams are to be maintained in a drawn down state as much as practical, so that sufficient capacity is available to capture water from subsequent storm events and minimising the risk of a wet weather overflow. Following a rainfall event, water held within contaminated water dams may be pumped to MWDs.

Contaminated water dam SD10 has an additional 'reuse zone' to provide operational capacity for the CHPP. SD10 has an additional 'reuse zone' for storage of 38.4 ML (on top of a 'sediment zone' for storage of 13.0 ML of sediment). Water can be stored in the 'reuse zone' of SD10 on a long term basis. The 'storm zone' would need to be maintained in a drawn down state. Excess water captured in contaminated water dams can be pumped to the MWDs and/or the pit, mitigating potential overflows.

3.3.2.2 Mine water dams

MWDs hold water of similar quality to the contaminated water dams. However, they generally only receive runoff from a small surface water catchment (i.e. they are primarily a permanent storage facility and are likely to have a 'turkey's nest' configuration). The MWDs are intended to receive and store contaminated water pumped from the sediment dams, contaminated storage dams or in-pit areas. MWDs may also hold imported water as outlined in Section 4.5.3 and will store water on a long term basis. The dams are operated with a freeboard sufficient to contain the 100 year ARI 72 hour duration storm event (refer to Section 4.4.3).

The design of MW5 was based on previous water balance modelling to the criteria of achieving retention of contaminated water generated within the site based on pit dewatering under historical climate conditions. The results of the water balance modelling indicate that the MWDs, as designed, are not expected to overflow. However, a spillway will be provided to allow for the contingency of an emergency overflow. Boggabri Mine MWDs are not prescribed dams listed under the NSW Dam Safety Regulation so are not subject to specific design requirements under this regulation.

3.3.3 Clean water dams

Clean water highwall dams capture runoff from undisturbed catchments ahead of the pit where reasonable and feasible in order to reduce inflows to the pit and maintain more natural flows in the downstream creek system. Highwall dams are to be maintained in a drawn down state, and are to be pumped out following a rainfall event of sufficient depth to result in runoff entering the dam. Where water quality meets the EPL discharge quality criteria highwall dams will be pumped out to the creek system.

Clean water highwall dams are sized to capture runoff from the 100 year ARI 24 hour storm event for the remnant catchment, assuming a runoff coefficient of 0.4 for undisturbed areas. Extreme events in excess of this capacity will spill into the pit. The pump-out systems for highwall dams are sized to empty the dam within 10 days. Clean water highwall dams are only present for the 2033 conceptual layout plan. In 2033 water from the clean water dams will be pumped to the east and then south around the edge of the mine disturbance area. The pumped clean water will be discharged into an existing drainage line/natural depression, which flows back to Nagero Creek north of the rail loop. Where required erosion sediment control measures will be used to minimise the potential for erosion at the pump outlet.

3.3.4 Diversion drains

Clean, dirty and contaminated water diversion drains are to be designed to convey the peak flow rate from a 100 year ARI time of concentration (t_c) storm event.

3.4 Existing water management system

The existing water management system is shown in Figure B-2 and schematically in Figure B-6, Appendix B. A summary of the existing storage characteristics is provided in Table C 1, Appendix C. The 'required minimum capacity' in Table C 1 is the minimum capacity required to store the design event and the nominated sediment allowance.

Existing MWD MW2 has a capacity 175.8 ML. Existing MWD MW3 has a capacity of 116.4ML. The total out-of-pit MWD storage in MW2 and MW3 is 292.2 ML.

Contaminated water dams SD28 (capacity 3.5 ML) and SD29 (capacity 10.5 ML) were commissioned at the beginning of 2015 as part of the MIA and CHPP upgrades. SD12 was upgraded in 2015 to a capacity of 200 ML (previous capacity 25.9 ML). The upgrade to SD12 catered for the expanded MIA and CHPP and haul road catchments.

Temporary in-pit mine water storage is provided to cater for surplus mine water in-pit until additional out-of-pit mine water storage is constructed onsite. The temporary storage is a segregated void area within the advancing mining pit area (Strip #9).

A diversion drain ahead of the mining void diverts runoff from undisturbed areas to the north of the mining void into the Nagero Creek system. Remnant undisturbed catchments to the east of the pit void drain directly into the mining void and this water is managed within the contaminated water management system.

An existing topsoil stockpile is situated to the north west of the clean water diversion drain ahead of the mining void. Temporary erosion and sediment measures control runoff from disturbed areas. Erosion and sediment controls are outlined in the SWMP.

Sediment dam SD3 was upgraded in 2015 to a capacity of 100 ML (previous capacity 31.8 ML). This upgrade catered for the expanding overburden catchment from 2015 to 2019. As the topography of the overburden dump does not allow for water stored in SD7 to be released to the creek system, water stored in SD7 is reused onsite.

A diversion drain diverts overflows from the Tarrawonga Coal Mine (TCM) northern waste rock emplacement area dams around the BCOPL MIA. The TCM diversion drain does not interact with BCOPL onsite water storage infrastructure.

A summary of the existing discharge points is provided in Table C 2, Appendix C. These are the existing discharge points and types listed in Section P1.3 of the EPL (12407, 4 April 2016).

3.5 2018 water management system

An indicative layout of the proposed 2018 water management system is shown in Figure B-3 and schematically in Figure B-7, Appendix B. A summary of the proposed 2018 storage characteristics is provided in Table C-3, Appendix C.

Existing MWD MW2 (capacity 175.8 ML) is planned to be decommissioned in 2017 as mining disturbs this area. A new MWD, MW5 (capacity 2000 ML), will be commissioned to replace MW2. Mine water from the mining void will be pumped to MWDs MW5 or MW3. The total out-of-pit MWD storage in MW3 and MW5 will be 2116.4 ML. Strips #9 and #45 will be mined through by 2017. However, water will still be stored in-pit during extreme wet weather. The borefield will be commissioned and be in operation during 2017.

An existing topsoil stockpile is situated to the north west of the clean water diversion drain ahead of the mining void. Pre-stripping occurs to the north east of the clean water diversion drain ahead of the mining void. Temporary erosion and sediment controls will

be installed to control runoff from disturbed areas. Erosion and sediment controls are outlined in the SWMP.

A summary of the proposed 2018 discharge points is provided in Table C-4, Appendix C. EPL discharge points will be reviewed and updated in consultation with the Environment Protection Authority (EPA). Discharge criteria are outlined in the SWMP.

An existing topsoil stockpile is situated to the north west of the clean water diversion drain ahead of the mining void. Pre-stripping occurs to the north east of the clean water diversion drain ahead of the mining void. Temporary erosion and sediment controls will be installed to control runoff from disturbed areas. Erosion and sediment controls are outlined in the SWMP.

A summary of the proposed 2018 discharge points is provided in Table C 4, Appendix C. EPL discharge points will be reviewed and updated in consultation with the EPA.

3.6 2022 water management system

An indicative layout of the proposed water management system is shown in Figure B-4 and schematically in Figure B-8, Appendix B. A summary of the proposed 2022 storage characteristics is provided in Table C 5, Appendix C.

A new dirty water sediment dam SD14 will be provided to cater for runoff from the cleared area ahead of the mining void. The topography of the overburden dump will allow water stored in SD7 to be released to the creek system following settling (assuming that the EPL discharge criteria is met).

A new diversion drain will divert runoff from the active overburden dump, as well as overflows from SD7 to SD3. SD3 will be upgraded in 2022 to a capacity of 209 ML (from existing capacity of 100 ML). Note that the upgrade to SD3 in 2022 is required as it is no longer proposed to commission sediment dam SD13 (as proposed in the EA) within the overburden emplacement area and storage capacity previously allocated to SD13 is now provided in SD3. Alternatively, if SD3 remains at 100 ML in 2022, it may be necessary to provide the appropriate additional storage capacity elsewhere.

A summary of the proposed 2022 discharge points is provided in Table C-6, Appendix C. EPL discharge points will be reviewed and updated in consultation with the Environment Protection Agency.

3.7 2033 water management system

An indicative layout of the proposed water management system is shown in Figure B-5 and schematically in Figure B-9, Appendix B. A summary of the proposed 2033 storage characteristics is provided in Table C 7, Appendix C.

New dirty water sediment dams SD19, SD20, SD21, SD22 and SD24 will be provided to cater for runoff from the expanded spoil dump. SD7 will be decommissioned by 2033 as the overburden catchment draining to this sediment dam is expected to be fully rehabilitated.

New clean water highwall dams CD5, CD6, CD7 and CD8 will be provided to minimise inflows from the natural catchment to the mining void. The highwall dams will be pumped

out to the Nagero Creek system, however, they will overtop to the mining void during large storm events.

A summary of the proposed 2033 discharge points is provided in Table C-8, Appendix C. EPL discharge points will be reviewed and updated in consultation with the Environment Protection Authority.

4. Site water balance model methodology

4.1 Modelling approach

A water balance model of the water management system of Boggabri Coal Mine was developed. The model was used to quantify the water inflows (rainfall, catchment runoff, groundwater inflows, water imported from the borefield and the Namoi River) and outflows (evaporation, CHPP usage, dust suppression usage), and likely range of water deficits, surpluses and discharges from Boggabri Coal Mine.

The SWB model is used as a strategic planning tool to assess the performance of the water management system for the Boggabri Coal Mine under a wide range of climate scenarios (sampled from a historical rainfall record) that may occur over the life of the Project.

The water balance is modelled as lumped mass balance and considered each storage in the water management system. A site specific water balance equation was derived from the catchment scale water balance equation as described in Ladson (2008). The water balance equation applies conservation of mass to derive an ordinary differential equation governing the volume V in each storage varying through time t :

$$\frac{dV}{dt} = P \cdot A(V) + R(S, P, E_t) \cdot C \left(1 - \frac{A(V)}{\|C\|} \right) + G + I - E \cdot A(V) - O$$

where:

- P , E and E_t were precipitation, potential open water evaporation and potential evapotranspiration sampled concurrently from the historical record as described in Section 2.2;
- $A(V)$ was the water surface area of the storage as described in Section 4.4.1;
- $R(S, P, E_t)$ was the runoff for each surface type estimated using the AWBM as described in Section 2.4 (which accounts for the soil moisture state S);
- C was the catchment area reporting to the storage distributed over the landuse types,
- G was the groundwater inflows; I was the pumped and surface transfers into the storage and O was the pumped and surface transfers out of the storage.

Effectively, the change in site water storage is simply the sum of all water inflows (rainfall, catchment runoff, groundwater inflows and pumped transfers into the site) minus all water outflows (evaporation and pumped transfers off site).

The evaporative losses and pumped outflow were limited by the available volume in the storage. If the volume exceeded the capacity C of the storage, the discharge, or overflow, rate D was calculated as:

$$D = \frac{dV}{dt} \quad \text{if } V > C$$

4.2 Numerical implementation

The water balance model of the Boggabri Coal Mine was implemented using GoldSim 11.1.5. GoldSim is computer simulation software widely used for mine site water balance studies. GoldSim uses the forward Euler method to solve the equations described in Section 4.1. A basic timestep of 1 day was used with shorter time steps inserted to represent the switching of pumps.

The water management system plans and schematics provided in Appendix B show the layout and interconnectivity of storages for the mine site.

The GoldSim model was used to simulate the water management system for an 18-year duration (i.e. from 2016 to 2033). The model simulated 127 realisations (i.e. sequences) of climate data and probability distributions of the model variables were summarised from the set of results from each realisation.

4.3 Modelling assumptions

The following assumptions are included in the water balance model:

- Pumping operations based on the existing and proposed infrastructure has been included in the water balance model. It is assumed that pumping occurs at an average pump rate and no allowance has been made for changes of flow rate with changes in head.
- Low flow outlets from dirty water sediment dams are opened after a period of two days of no rainfall. This was assumed to be sufficient period for water quality criteria to be met. Low flow outlets have been represented in the water balance model such that the dams empty over a period of three days.
- The bottom half of the 'sediment zone' of dirty water sediment dams and contaminated water dams is half full of sediment throughout the simulation. Water that ponds in the top half of the 'sediment zone' evaporates over time and is not used to supply dust suppression water or CHPP process water.
- No allowance has been made for seepage from water storages.
- Diversion drains capture all runoff from their local catchments and there is no bypass of diversion drains.
- Adequate surface water allocations or alternative water sources are available to make-up the external water requirement. Where the annual external water requirement exceeds BCOPL's current water entitlements, it was assumed that BCOPL would secure additional water to make up the difference.
- The Tarrawonga Coal Mine (TCM) catchment area to Nagero Creek discharging across the western boundary of mining lease 1579 (at Tarrawonga's LDP1) discharges directly to Nagero Creek, bypassing the Boggabri Coal Mine water management system via a clean water diversion drain.

- While the model assesses the performance of the system under historical extremes that may reasonably be expected to recur in the future. It does not explicitly consider the potential impact of future climate change.
- MW2 and Strip #9 are mined through and MW5 is commissioned as a mine water storage in 2017 (assumed to occur on 1 July 2017) .
- SD7 is diverted to SD3 at 1 January 2022 and the capacity of SD3 is increased from 100 ML to 209 ML at 1 January 2021.
- The borefield, as approved as part of MOD 5, is commissioned and becomes fully operational of 1 July 2017.
- The mine development over the life of the Project was represented in the model by linearly interpolating between the existing, 2018, 2022 and 2033 'snapshot' landforms. The interpolation of catchment areas between the snapshots is compared to the assumptions of staging of MW2, Strip #9, MW5, SD7 and SD3 in Figure 4.1.

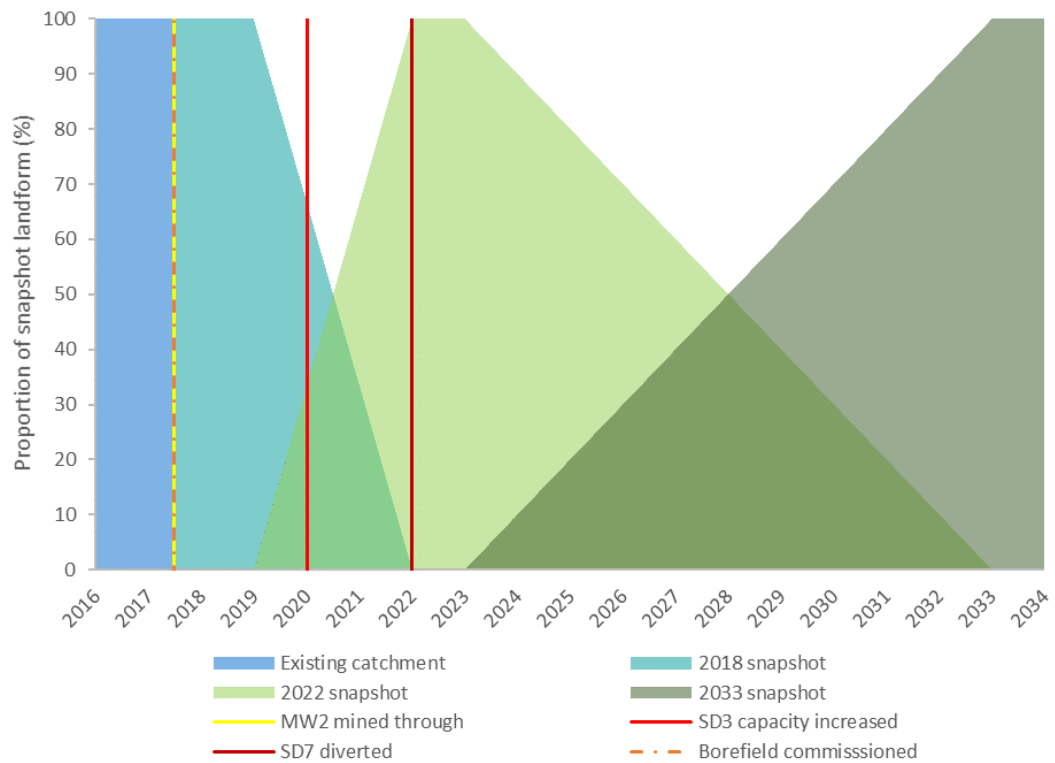

Figure 4.1 Interpolation of snapshot catchment areas and staging assumptions

4.4 Site data

4.4.1 Storages

The storages in the water balance model are summarised in Table 4-1. The capacities are summarised from Table C.1, Table C.3, Table C.5 and Table C.7, referred to in Appendix C. The maximum water surface areas were measured from elevation data for existing storages, and design spatial data for future storages. The shape factor was used to estimate the geometry of storages for which stage storage relationships were not available. The value of the factor was inferred from elevation data and site experience and may vary from a value of 0, corresponding to a prismatic shape, to a value 1, corresponding to pyramidal shape.

Table 4-1 Storages

Storage	Capacity (ML)	Maximum water surface area (ha)	Shape factor
MW2	175.8	1.1	NA
MW3	153.5	5.6	0.2
MW5	2000.0	15.8	0.6
Pit	10 000 (nominal)	100 (nominal)	0.3
SD10	116.4	3.3	0.3
SD11	16.4	0.5	0.3
SD12	206.6	3.0	0.3
SD14	72.7 (design)	3.6	0.3
SD19	179.9 (design)	6.34	0.3
SD20	41.8 (design)	2.2	0.3
SD21	55.6 (design)	2.7	0.3
SD22	2.4 (design)	0.2	0.3
SD23	9.5	0.8	0.4
SD24	7.3 (design)	0.3	0.4
SD28	3.5	0.3	0.3
SD29	10.5	0.5	0.3
SD3	102.3 (increased to 209.3 in 2022)	2.3	0.3
SD6	52.2	1.9	0.3
SD7	95.1	2.4	0.3
SD8	9.8	0.9	0.5
Strip #9	3426	5.8	0.4

The 'pit' storage corresponds to a number of storages (currently (Strip 45, MW4 and MW6) that are in the pit void or would spill into the pit void. These storages are relatively temporary and vary with open cut mining operations. Therefore they have been grouped as a nominal 'pit' storage that also includes all other such storages that may exist in the future as the open cut pit void develops.

In order to calculate direct rainfall and actual evaporation, the water surface area of each storage was calculated from the stage storage relationships where available (for MW2), referred to in Table D-1 of Appendix D. For other storages, the water surface area A corresponding the water volume V was approximated using the approach described in Brooks and Hayashi (2002) from the maximum surface area A_{max} estimated from elevation data, the capacity C and the shape factor p as:

$$A = A_{max} \left(\frac{V}{C} \right)^p$$

4.4.2 Catchments

Catchment areas adopted in the water balance model are provided in Table 4.2. The study catchment was Nagero Creek to the point where the creek meets the floodplain approximately 1 km downstream of Boggabri Coal Mine.

Table 4-2 Catchment areas

System	Storage	Existing	2018	2022	2033
Boggabri Coal Mine contaminated water dams ¹	MW2	5	-	-	-
	MW3	22	22	22	22
	MW5	-	15	15	15
	SD10	27	27	27	27
	SD11	4	4	4	4
	SD12	64	53	53	53
	SD28	1	1	1	1
	SD29	4	4	4	4
	Strip #9	22	-	-	-
	Pit	899	857	402	535
	<i>Subtotal</i>	<i>1049</i>	<i>984</i>	<i>528</i>	<i>661</i>
Boggabri Coal Mine dirty water dams	SD3	140	213	642	198
	SD6	64	64	64	64
	SD7	159	229	247	0
	SD8	13	13	13	13
	SD14	-	-	313	-
	SD19	-	-	-	415
	SD20	-	-	-	101
	SD21	-	-	-	127
	SD22	-	-	-	6
	SD23	20	20	20	20
	SD24	-	-	-	17
		<i>Subtotal</i>	<i>396</i>	<i>539</i>	<i>1299</i>
Boggabri Coal Mine clean water dams	CD5	-	-	-	20
	CD6	-	-	-	21
	CD7	-	-	-	103
	CD8	-	-	-	18
	<i>Subtotal</i>	<i>-</i>	<i>-</i>	<i>-</i>	<i>162</i>
Rehabilitation released directly to Nagero Creek		-	-	-	466
TCM water management system within Nagero Creek catchment ²		400	400	400	400
Undisturbed Nagero Creek catchment		2431	2353	2049	1626
Total		4275	4275	4275	4275

¹ Excludes approved irrigation area draining to Bollol Creek catchment.

² TCM lease area within Nagero Creek catchment assumed based on proposed operations at TCM.

The area of rehabilitated catchment increases from existing conditions to 2033. Progressive rehabilitation is undertaken and where the landform is stable with no sediment laden or otherwise polluted runoff, then runoff from catchment areas is returned to the natural system. While some of the rehabilitated areas have been rehabilitating for approximately five years, this rehabilitated area is unable to be segregated from the remaining overburden dump. For this reason, runoff from rehabilitated areas occurs only in 2033 when the clean water can be segregated from the dirty water runoff, captured and released.

4.4.3 Operating rules

The modelled rules for the operation of the pumps and outlets are summarised in Table 4-3. The pumps were modelled to switch on and the valves modelled to open when the *on trigger* occurred if the *conditions* were true. The pump remained on and the valve remained open until the *off trigger* occurred or the *conditions* became false. The low operating volumes (LOV) and high operating volumes (HOV) are summarised in Table 4-4.

The dewatering and release of sediment basins was subject to two site wide conditions:

- *Contaminated water excess*: the site was in contaminated water excess if the total volume of contaminated water exceeded the capacity of the contaminated water storages. Effectively, this prevented reuse of dirty water if there was water in -pit.
- *Discharge allowed*: offsite releases from dirty water dams were allowed if there had been a 2 day period without rainfall. This condition was assumed to approximate the time required for the water quality in the dirty water storages to reach an adequate standard to allow off-site release.

The dewatering of contaminated storages to MW2 or MW5 was not constrained by the volume in these storages. If the volume in MW2 and MW5 exceeded the HOV, the transfer was diverted to Strip #9 until it was mined through and afterwards to the pit.

Table 4-3 Operating rules

Pump / Valve	Pump rate (ML/day)	On trigger	Off trigger	Conditions
Dewater SD10 to MW2/MW5	10.0	SD10 greater than HOV	SD10 less than HOV	MW5 less than HOV
Dewater SD10 to MW3	10.0	SD10 greater than HOV	SD10 less than HOV	MW3 less than HOV MW2/MW5 greater than HOV
Dewater SD10 to Strip #9 or Pit	10.0	SD10 greater than HOV	SD10 less than HOV	MW3 greater than HOV MW2/MW5 greater than HOV
Dewater SD11 to SD10	2.0	SD11 greater than HOV	SD11 less than LOV	SD10 less than HOV
Dewater SD12 to MW2/MW5	20.0	SD12 greater than HOV	SD12 less than LOV	
Dewater SD28 to SD11	1.0	SD28 greater than HOV	SD28 less than LOV	SD11 less than HOV
Dewater SD29 to SD11	1.5	SD29 greater than HOV	SD29 less than LOV	SD11 less than HOV
Dewater Pit to MW2/MW5	5.0 (10.0 if pit volume)	Pit greater than HOV	Pit less than LOV	MW2/MW5 less than HOV

Pump / Valve	Pump rate (ML/day)	On trigger	Off trigger	Conditions
	exceeds 200 ML)			
Makeup Strip #9 to MW2/MW5	5.0	MW2/MW5 less than LOV	MW2/MW5 greater than HOV	Pit less than HOV Strip #9 greater than LOV
Makeup MW2/MW5 to SD10	5.0	SD10 less than LOV	SD10 greater than HOV	MW2/MW5 greater than LOV
Makeup MW3 to SD10	3.5	SD10 less than LOV or MW3 greater than HOV	SD10 greater than HOV or MW3 less than LOV	MW3 greater than LOV and SD10 less than HOV
Dewater SD3 to SD12	5.0	SD3 greater than HOV	SD3 less than LOV	SD12 less than HOV Not contaminated water excess
Dewater SD19 to MW2/MW5	20.0	SD19 greater than HOV	SD19 less than LOV	Not contaminated water excess
Dewater SD23 to MW5	3.0	SD23 greater than HOV	SD23 less than LOV	Not contaminated water excess
Dewater SD6 to SD10	2.0	SD6 greater than HOV	SD6 less than LOV	SD10 less than HOV Not contaminated water excess
Dewater SD8 to SD6	1.0	SD8 greater than HOV	SD8 less than LOV	SD6 less than HOV Not contaminated water excess
Release SD3 to Creek (valve)	40.0	SD3 less than 40 ML below capacity	SD3 more than 40 ML below capacity	Rainfall exceed 1 mm/day
Release SD14 to Creek (valve)	17.0	SD14 greater than HOV	SD14 less than LOV	Discharge allowed
Release SD19 to Creek (valve)	62.0	SD19 greater than HOV	SD19 less than LOV	Discharge allowed and pump not on
Release SD20 to SD19 (valve)		SD20 greater than HOV	SD20 less than LOV	Discharge allowed
Release SD21 to Creek (valve)		SD21 greater than HOV	SD21 less the LOV	Discharge allowed
Release SD22 to Creek (valve)		SD22 greater than HOV	SD22 less than LOV	Discharge allowed
Release SD23 to Creek (valve)		SD23 greater than HOV	SD23 less than LOV	Discharge allowed
Release SD24 to Creek (valve)		SD24 greater than HOV	SD24 less than LOV	Discharge allowed
Release SD6 to Creek (valve)		SD6 greater than HOV	SD6 less than LOV	Discharge allowed and pump not on
Release SD8 to SD6 (valve)		SD8 greater than HOV	SD8 less than LOV	Discharge allowed and pump not on
Release CWDs to Creek (valve)		CWD greater than HOV	CWD less than LOV	

Table 4-4 Assumed operating volumes

Storage	LOV (ML)	HOV (ML)
MW2	87.7	163.6
MW3	5.0	131.0
MW5	1000.0	1994.9
Strip #9	5.0	3369.3
Pit sump	5.0	10.0
SD10	19.4	61.7
Contaminated water dams (except SD10)	Sediment zone volume less 1 ML	Sediment zone volume
Dirty water sediment dams	Sediment zone volume less 1 ML	Sediment zone volume
Clean water dams	0	1

Due to the approximations required to model the importation of water into the site, as discussed in Section 4.5.3, the import of water from the borefield and the Namoi River was modelled according to the following rules:

- If the volume in either SD10 or MW2/MW5 fell below the LOV, water was supplied to meet the simulated CHPP and dust suppression demand and the simulated evaporative losses at up to the maximum borefield extraction rate, with SD10 given the first preference.
- If the volume in either SD10 or MW2/MW5 fell below a nominal low threshold of 5 ML, water was supplied from the river to meet the simulated CHPP and dust suppression demands and the simulated evaporative losses.

The effect of this was to maximise the use of available extraction capacity of borefield until the site had exhausted the storages on site, before importing water the river.

4.5 Water sources

Water sources for the BCM comprise:

- rainfall-runoff
- groundwater inflows to the mining void
- imported water

4.5.1 Rainfall and runoff

Contaminated surface water runoff is captured in dams or the mining void and stored for onsite reuse. Dirty water runoff is also captured in sediment dams for settling of suspended solids prior to discharge to Nagero Creek (assuming that water quality criteria are met).

The volume of inflows into each storage was calculated as the sum of the direct rainfall on to the water surface and the surface water runoff. The volume of direct rainfall was calculated as the product of the simulated rainfall depth (refer to Section 2.2) and area of water storages, calculated as described in Section 4.4.1. The volume of catchment runoff was calculated as the product of the catchment area (refer to Section 4.4.2) and the runoff depth calculated using the AWBM as described in Section 2.4.

4.5.2 Groundwater inflows to mining void

Seepage rates of groundwater into the mining void have been estimate from the results of the Continuation of Boggabri Coal Project Groundwater Assessment (AGE, October 2010). The estimate adopted was a worst case cumulative groundwater impact assessment considering cumulative impacts associated with the concurrent operation of the Boggabri, Tarrawonga and Maules Creek coal mines. A summary of the groundwater inflows adopted in the water balance model is provided in Figure 4.2.

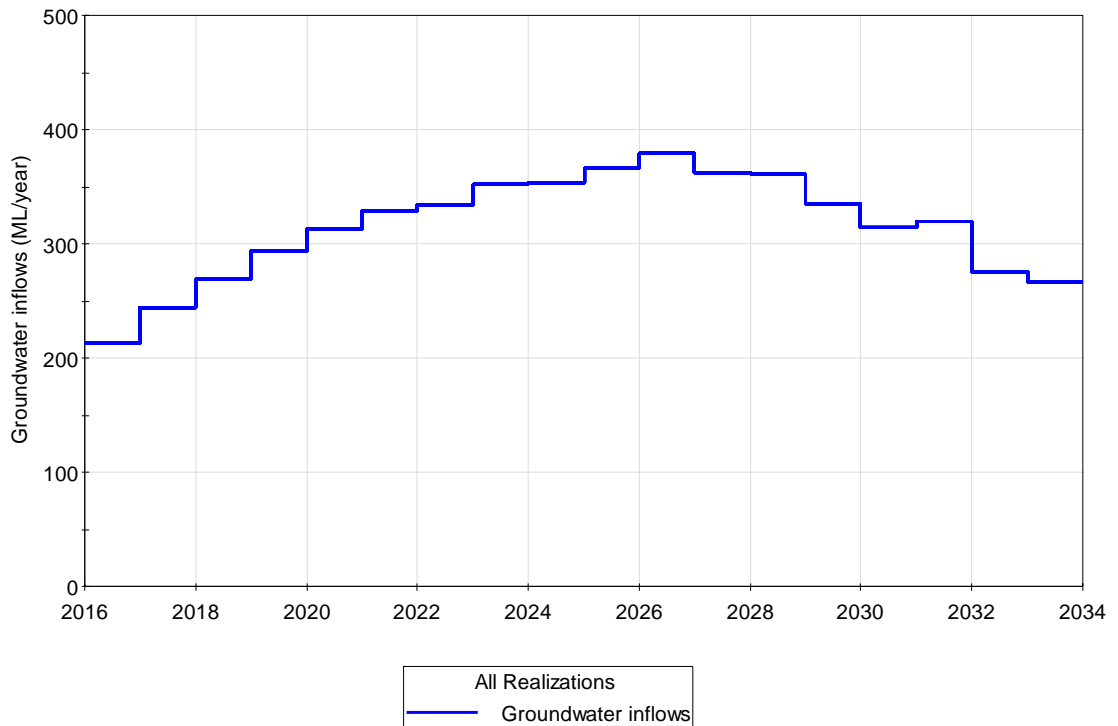

Figure 4.2 Estimated groundwater inflows to mining void

From Figure 4.2 it can be seen that groundwater inflow to the mining void is expected to increase until approximately 2026. After 2026, it is predicted that groundwater make within the mine void at Boggabri may be reduced by up to 40 % due to cumulative impacts from operations at Tarrawonga and Maules Creek coal mines. Some of the predicted pit inflows will be lost through evaporation, however inflows that collect in the mine void will be pumped to mining water storages for onsite reuse.

4.5.3 Imported water

4.5.3.1 Groundwater entitlements

BCOPL currently holds licences for the Upper Namoi Zone 4 Namoi Valley Groundwater Source and the Gunnedah-Oxley Basin. Details of these water access licences (WALs) are provided in Table 4-5.

Table 4-5 Summary of groundwater WALs currently held by BCOPL

Source	WAL category	WAL No.	Share (units)	Expiry	Current reliability (%)
Groundwater					
Upper Namoi Zone 4 Groundwater Source	Aquifer	WAL 15037	172	Perpetuity	95-100
Upper Namoi Zone 4 Groundwater Source	Aquifer	WAL 24103	275	Perpetuity	95-100
Upper Namoi Zone 4 Groundwater Source	Aquifer	WAL 12691	457	Perpetuity	95-100
Upper Namoi Zone 4 Groundwater Source	Aquifer	WAL 12767	3	Perpetuity	95-100
Upper Namoi Zone 4 Groundwater Source	Aquifer	WAL 36547	37	Perpetuity	95-100
Upper Namoi Zone 4 Groundwater Source	Aquifer	WAL 37519	84	Perpetuity	95-100
Total			1028		
Groundwater – pit interference					
Gunnedah-Oxley Basin MDB	Aquifer	WAL 29562	700	Perpetuity	100
Gunnedah-Oxley Basin MDB	Aquifer	WAL 29473	142	Perpetuity	95-100
Total			842		

A total of 1028 unit shares of groundwater would be available to BCOPL from the aquifer access licences for the Upper Namoi Zone 4 Groundwater Source. The actual volume of groundwater available would depend on the Available Water Determinations (AWD) made under the Water Sharing Plan (WSP), these are likely to be at or close to 1 ML per unit share from the water access licences. Water derived from the pit inflows can be reused onsite under WAL29562 providing further capacity for supplementation.

BCOPL currently uses groundwater pumped from Lovton and Daisymede Bore for existing operations. BCOPL has approval to expand its bore water supply network within alluvial aquifer to include additional bores on BCOPL and privately owned land. BCOPL will possess the necessary additional WALs required to extract water from the approved borefield.

Groundwater pumped from Daisymede Bore is currently used onsite for potable water and vehicle washdown, as well as dust suppression. Groundwater pumped from Lovton Bore is used for amenities and fire suppression.

Groundwater can also be traded on a temporary or permanent basis within the greater Gunnedah-Oxley Basin Groundwater Source, and within Zone 4 of the Upper Namoi Valley (Keepit Dam to Gins Leap) Ground Water Source, subject to local impact considerations.

4.5.3.2 Surface water entitlements

BCOPL currently holds general security and supplementary water access licences for the Lower Namoi Regulated River Water Source. Details of these water access licences are provided in Table 4-6. The total share component under these licences is 422 unit shares of

general security water and 32.2 unit shares of supplementary water. The actual volume of river water available to BCOPL from the general security licences would depend on the Available Water Determinations (AWD) made from time to time in accordance with the Water Sharing Plan for the Upper Namoi and Lower Namoi Regulated River Water Sources 2003. Supplementary access is also ‘announced’ from time to time, and is dependent on the presence of unregulated flows in the regulated river, and on the operation of the WSP rules.

Table 4-6 BCOPL water access licences for Lower Namoi Regulated River Water Source

Source	Water Access Licence category	Water Access Licence number	Share component (units)
Lower Namoi River	General Security	WAL 2571	51
Lower Namoi River	General Security	WAL 2595	243
Lower Namoi River	Supplementary Water	WAL 2596	26.6
Lower Namoi River	Supplementary Water	WAL 2572	5.6
Upper Namoi River	General Security	WAL 37067	128

The Namoi Regulated River water sharing plan estimates that there are in total 256,400 unit shares of general security access licences and 115,000 unit shares of supplementary water access licences. Access to entitlement will vary from year to year depending on climatic conditions and water availability.

A continuous accounting system is used in the Namoi Valley for general security entitlements. The maximum that may be held in an account is 2.0 ML per unit share. The amount carried over from one year to the next is unlimited (maximum account balance effectively limits carryover volumes). The maximum usage (including trade) in any season is 1.25 ML per unit share. The maximum water use over any 3 consecutive years is 3.0 ML per unit share (Ribbons, 2009).

BCOPL is able to access surface water from the Namoi River in accordance with its surface water licences via a pump station from the Namoi River which has been constructed. BCOPL can also trade additional water, either temporarily or permanently, to make up shortfalls on a contingency basis.

4.5.3.3 Import water model

In the absence of detailed model of the entire Namoi River catchment, a conceptual model, consistent with the groundwater modelling described in Parsons Brinkerhoff (2015), was developed to estimate the likely volume extracted from the borefield and Lower Namoi River. The average rainfall over the previous four years was used as proxy for the water available for extraction from Lower Namoi Regulated River Source, and therefore in turn as a proxy for the likely borefield extraction rate, as shown in Figure 4.3. This model approximates the likely management of the borefield: during periods when water is available for extraction from the Lower Namoi Regulated Source, extraction from the borefield is likely be less than the maximum rate of 9.4 ML/day in order to minimise the risk of impact on surrounding water users. It was assumed that sufficient additional surface water access licences will be acquired when required and sufficient volume will be available from the Namoi River. The relationship between 4 year average rainfall and borefield extraction rate in shown in Figure 4.3. This model does not account for actual daily management of the borefield and river extraction, but it consistent with groundwater modelling described in Parsons Brinkerhoff (2015) and is representative the average of operational conditions.

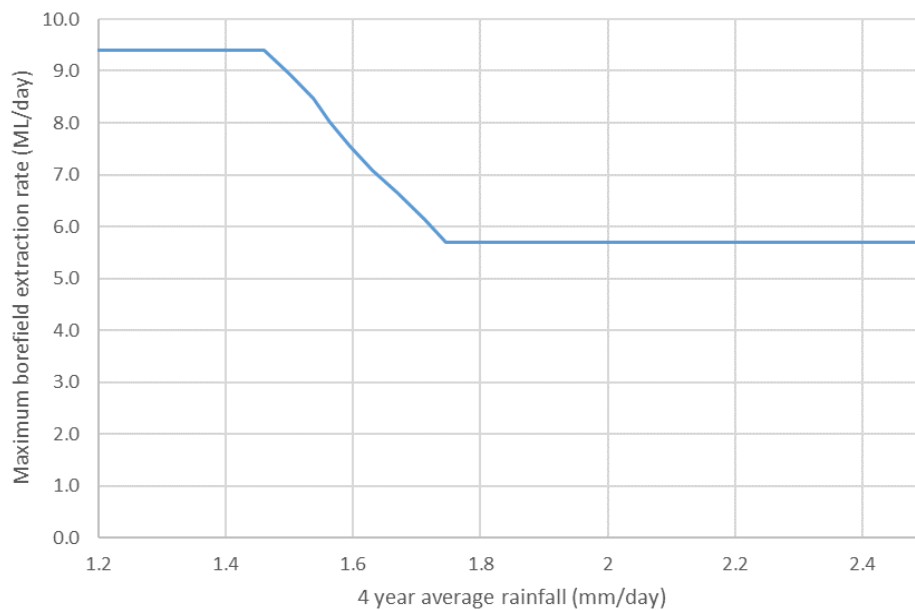

Figure 4.3 Assumed borefield extraction rate varying with 4 year average rainfall

4.6 Water demands

Water demands comprise:

- dust suppression water
- CHPP make-up water
- vehicle washdown water
- potable water (for drinking water and amenities)

Water demand information has been provided by BCOPL. The demands provided in the Boggabri Coal Project Surface Water Assessment (Parsons Brinckerhoff, 2010) were revised based on more detailed project design and engineering work that has occurred since the Surface Water Assessment was undertaken in 2010, and updated demand information in line with the latest revision of the MOP.

4.6.1 Dust suppression

Water is required for dust suppression on haul roads and other disturbed areas. Dust suppression for the CHPP coal stockpiles, coal crushing areas, and coal loading areas and MIA are accounted for in the CHPP demands (refer to Section 4.6.2).

BCOPL has provided revised estimates of dust suppression demands for the project. A summary of the haul road dust suppression demands adopted in the water balance model is provided in Table 4-7. Haul road dust suppression numbers have been revised following lodgement of the EA, largely due to adjustments to the MOP (refer to MOP Amendment A) and more detailed project design and engineering work having been undertaken. BCOPL estimates haul road dust suppression demand to be 4 ML/day on days when it is required.

Table 4-7 Haul road dust suppression demand estimates (average)

Project year	Dust suppression demand (ML/day)
Existing	4
2018	4
2022	4
2033	4

Historical water cart usage information is summarised in Figure 4.4. Variance in the amount of water used during later years is likely.

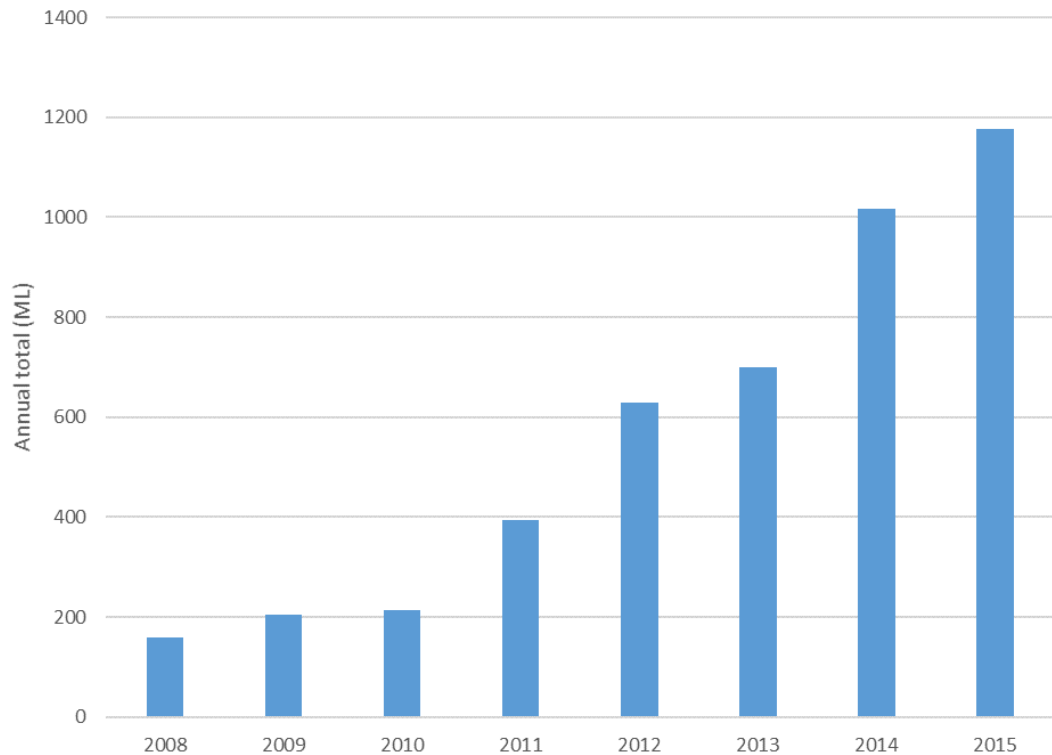

Figure 4.4 Observed water usage for dust suppression of haul roads

Water used for dust suppression at the mine site is sourced as a priority from recycled contaminated water contained in MW2 and MW3. When required, imported water will be used to supplement recycled water sourced from MW2 and MW3.

For the purposes of the water balance analysis, it is assumed that dust suppression water will not be required on days with a total rainfall depth for more than 5 mm. On average, approximately 35 days per year have more than 5 mm of rainfall based on the historical rainfall record.

4.6.2 Coal handling and preparation plant

BCOPL estimates the net CHPP water demand to be approximately 4 ML/day (equivalent to 1461 ML/annum). This water is required for coal washing, dust suppression and MIA washdown water. This is the net demand and accounts for water that is reused within the process. This net demand is simulated in the model as a constant flow rate. The assumption of constant flow rate is of suitable accuracy for the purpose of the SWB model as actual day to day variations in operations will be attenuated by the water storage on site.

The CHPP was commissioned in 2015 and processes up to 4.2 Mtpa of coal from Boggabri Coal Mine. The breakdown of CHPP demands is summarised in Table 4-8.

Table 4-8 CHPP demand estimates

Project year	Coal washery feed (Mtpa)	Annual CHPP demand (ML)
Existing	4.2	1,461
2018	4.2	1,461
2022	4.2	1,461
2033	4.2	1,461

4.6.3 MIA and potable water

Water is required for vehicle washdown in the MIA. Washdown water is recycled; however, water is required to make-up evaporative losses. Make-up water for vehicle washdown is currently sourced from groundwater pumped from Daisymede Bore.

Potable water is used in the administration building and amenities during operations. Potable water is currently sourced from groundwater entitlements (WAL 29473) assigned to the Lovton Bore. Wastewater from the administration building and amenities will be treated in an onsite Envirocycle treatment plant. Wastewater generated by the onsite Envirocycle treatment plant has not been considered in the water balance analysis.

BCOPL estimates that approximately 1 ML/day (equivalent to 365 ML/yr) of water will be required for the MIA and potable water. This net demand is simulated in the model as a constant flow rate. The assumption of constant flow rate is of suitable accuracy for the purpose of the SWB model as actual day to day variations in operations will be attenuated by the water storage on site.

4.7 Other losses

4.7.1 Evaporation

Evaporative losses from storages was calculated as the product of the evaporation depth for open water, as described in Section 2.2, and the water surface area of the storage, as described in Section 4.4.1.

Evaporative surface area for dams has been estimated as described in Section 4.4.1.

4.7.2 Seepage from dams

Some water will be lost from dams as a result of seepage through the foundation. Site dams should have low seepage losses and, depending on the subsoils, an engineered liner will be required. All dams are constructed with the best material available as water is a critical resource for BCOPL.

Water balance modelling has assumed seepage losses to be negligible. This assumption is intended to be conservative from the perspective of containment performance but may not be conservative for other outcomes of operational simulation modelling (such as water supply reliability).

4.7.3 Off-site releases

Modelled releases from site were comprised of:

- Pumped releases of clean water from high wall dams, that were modelled according to the operating rules in Section 4.4.3.
- Overflows of dirty water from dirty water dams due to rainfall events that exceeded the design rainfall event when the volume of storage exceeded the capacity of storage, as described in Section 4.1.
- Controlled releases of dirty water from dirty water dams, that were modelled according to the operating rules in Section 4.4.3. In reality, these releases will only occur when the water quality of the water is adequate, as described in Section 3.1.2.

5. Site water balance model validation

As part of the update of the site water balance model, site observations from 2013 to 2015 for Boggabri Coal Mine were used to update the calibration of the runoff model (described in Section 2.4) and to validate the model.

5.1 Data and assumptions

The data and assumptions used in the validation are summarised in Table 5-1.

Table 5-1 Validation data and assumptions

Data	Source	Assumptions
Storage water volumes	Observed storage volume for mine water dams on a weekly basis	Stage-storage relationship derived from the observed water levels and volumes.
CHPP usage	Estimated annual averages	1 ML/day from January 2015 to June 2015 and 4 ML/day from July 2015 onwards
Dust suppression usage	Observed from meters at truckfill points as monthly totals	Annual totals were distributed monthly by scaling seasonally with potential evaporation and calibrating to 2015 monthly totals.
MIA and potable use	Estimated annual average	MIA and potable demand was supplied exclusively by bores and that the bores contributed only to the MIA and potable demand at a constant 1 ML/day.
River extractions	Observed river extractions as monthly totals	The January 2016 was included in the 2015 annual total.

5.2 Runoff model calibration

A significant source of uncertainty in the SWB model is the estimation of catchment runoff. As described in Section 2.4, the Australian Water Balance Model (AWBM) is used to estimate the catchment runoff. AWBM is defined by nine parameters: three soil capacities; three proportional areas; and three recession parameters. The SWB model identified six land usage types, each with a unique set of AWBM parameters. As a result, runoff is parameterised by a total of 54 AWBM parameters. The previously adopted values for these 54 parameters were reviewed and found to be generally within the typical range adopted for the identified land use areas, however had not been calibrated to local conditions.

As the available observed data was limited to mostly total storage volumes, the capacity to refine the parameter values further was limited. Therefore, a simplified calibration approach was adopted, with a scale factor used to adjust the three soil moisture capacities for all land use type. This approach allows for the adjustment of modelled catchment runoff with a single parameter (the soil moisture storage scale factor) whilst preserving the variable soil storage pattern. Approximately, such a scale factor varies inversely with average annual catchment runoff.

In order to identify suitable values of the soil moisture scale factor, a Monte-Carlo sampling method was adopted. Using this method, values of the soil moisture scale factor are randomly sampled from a specified range, and the response of the water management system modelled using the SWB model. A total of 1000 parameter samples were modelled, for the period from 1/1/2013 to 1/1/2016 using the actual climatic conditions and assumed production demands.

The performance of the SWB model over the simulation period was measured by the difference between the total site demand to the observed imported volumes. A plot of this difference against the soil moisture scale factor is shown in Figure 5-1.

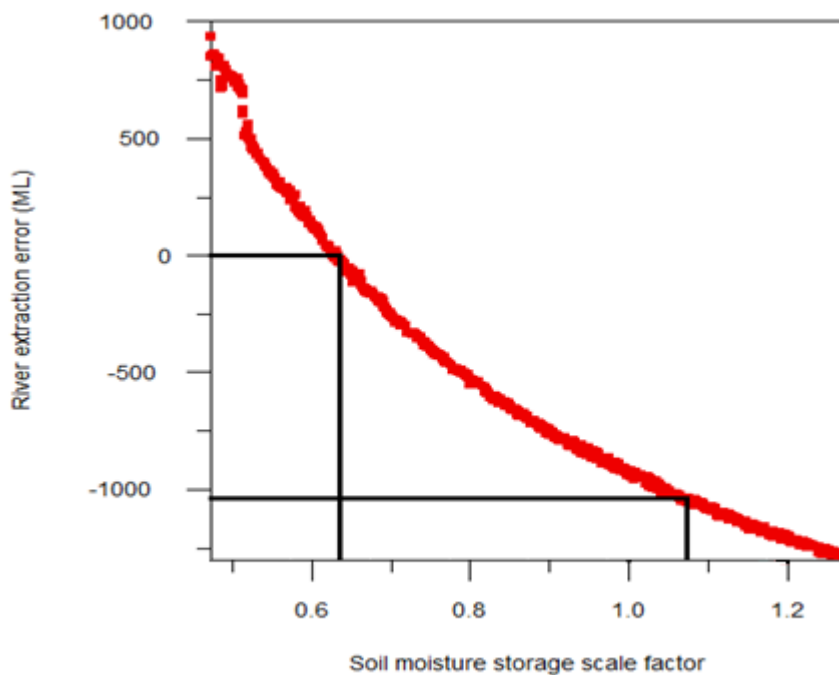

Figure 5-1 Calibration result - River extraction (observed minus modelled)

From Figure 5-1 it can be seen that the previous parameter set (a soil moisture storage scale factor of 1.0) overestimated river extraction requirements by approximately 1050 ML over the three year period modelled

From Figure 5-1 it can be seen that a soil moisture storage scale factor of 0.63 results in the modelled cumulative river extractions matching the observed river extractions. This soil moisture factor was adopted, and the corresponding C1, C2 and C3 parameter values for all land use types, as presented in Table 5-2, were used.

Table 5-2 Adopted AWBM parameter values

Landuse	BFI	K _{base}	A1	A2	A3	C1	C2	C3
Undisturbed	0.05	0.803	0.134	0.433	0.433	14.2	145.2	290.5
Rehabilitated spoil	0.2	0.98	0.134	0.433	0.433	3.6	36.4	72.9
Industrial	0	NA	0.134	0.433	0.433	1.4	14.4	28.8
Mining void	0	NA	0.2	0.2	0.6	3.2	44.1	56.7
Active spoil	0.8	0.7	0.3	0.3	0.4	18.9	37.8	75.6
Pre-strip	0.2	0.98	0.134	0.433	0.433	2.9	29.3	58.6

5.3 Validation

The calibrated SWB model was used simulate the site water balance over the calibration period (from 1/1/2013 to 1/1/2016) using the updated AWBM parameters. The modelled (or “hindcasted”) results were then compared against observations.

Due to the coarseness of the river extraction data (annual totals), the daily extraction rate was modelled such that it “targeted” the observed water volumes. This captured the variation in operations and river flow that cannot be replicated in the model.

The time series of the observed and modelled total storage volume shown in Figure 5-2. The total storage volume was considered as the total of MW2, MW3, SD10 and Strip #9, shown in Figure 5-3, Figure 5-4, Figure 5-5 and Figure 5-6 respectively. The monthly usage, river extraction and discharge is shown in Figure 5-7.

A satisfactory fit of modelled variables to observations was achieved by allowing the volume in the pit to increase to 600 ML after the rainfall event in March 2014. After November 2014, this volume was allowed to be drawn down. It is understood that this volume corresponds approximately to the reported capacity of Strip #45, however, no record of volume in strip storages other than Strip #9 were available to confirm that such a volume of water was stored on site during this period.

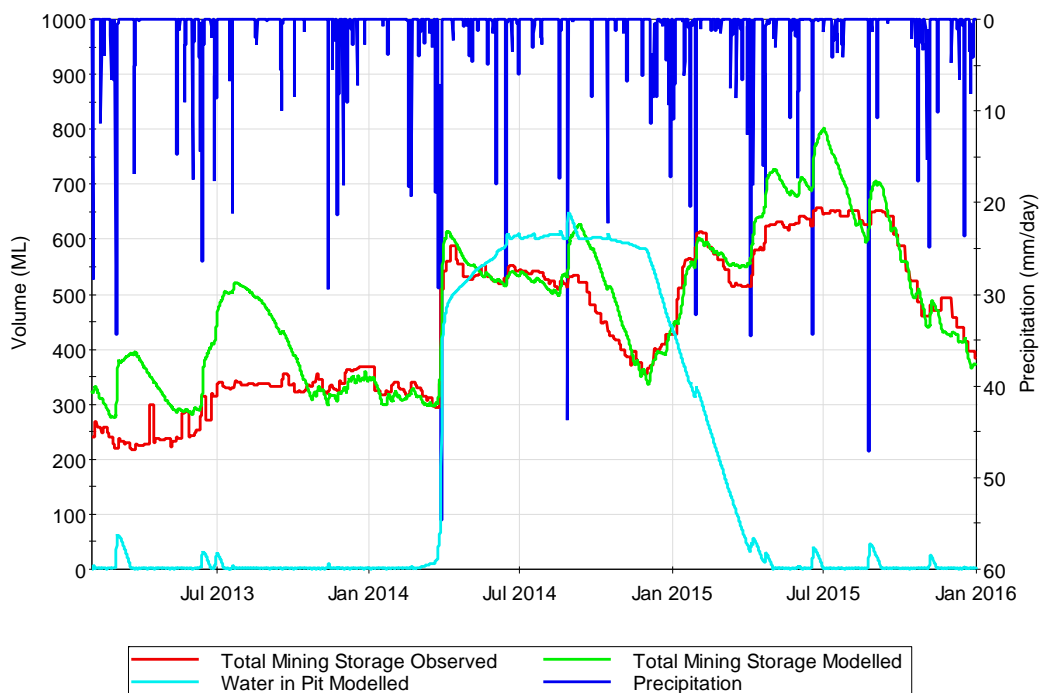

Figure 5-2 Observed and modelled total mining water storage volume

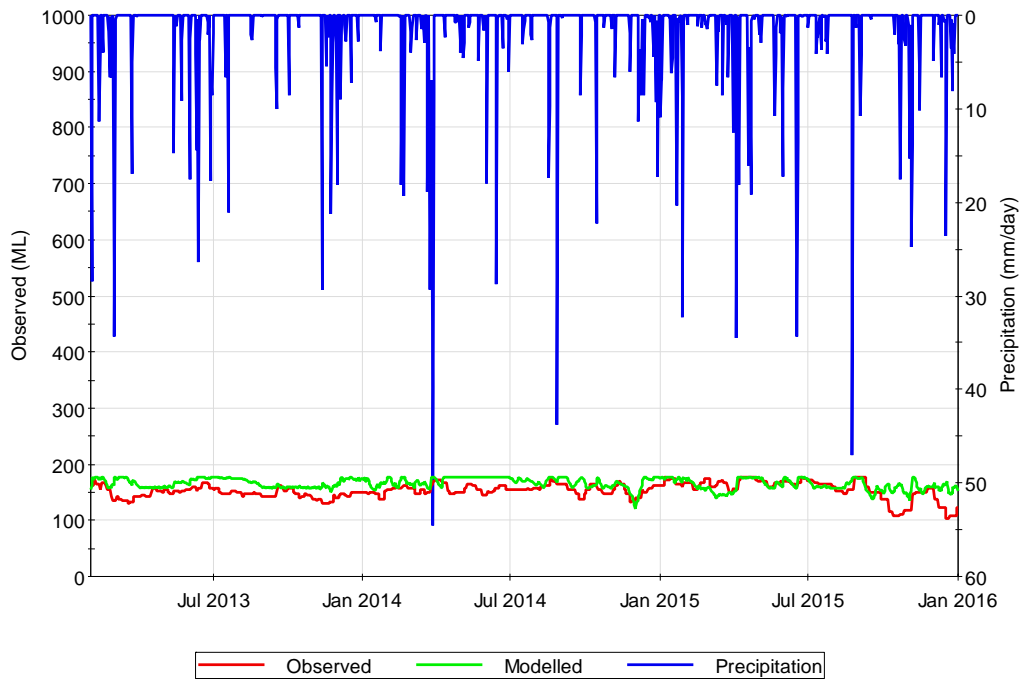

Figure 5-3 Observed and modelled MW2 water storage volume

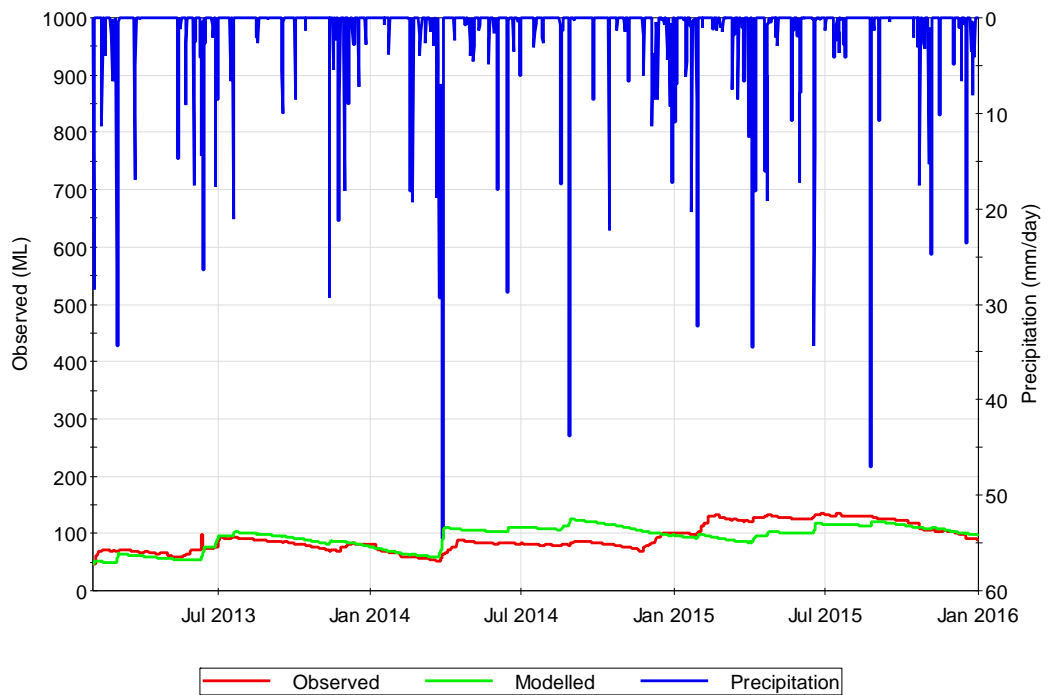

Figure 5-4 Observed and modelled MW3 water storage volume

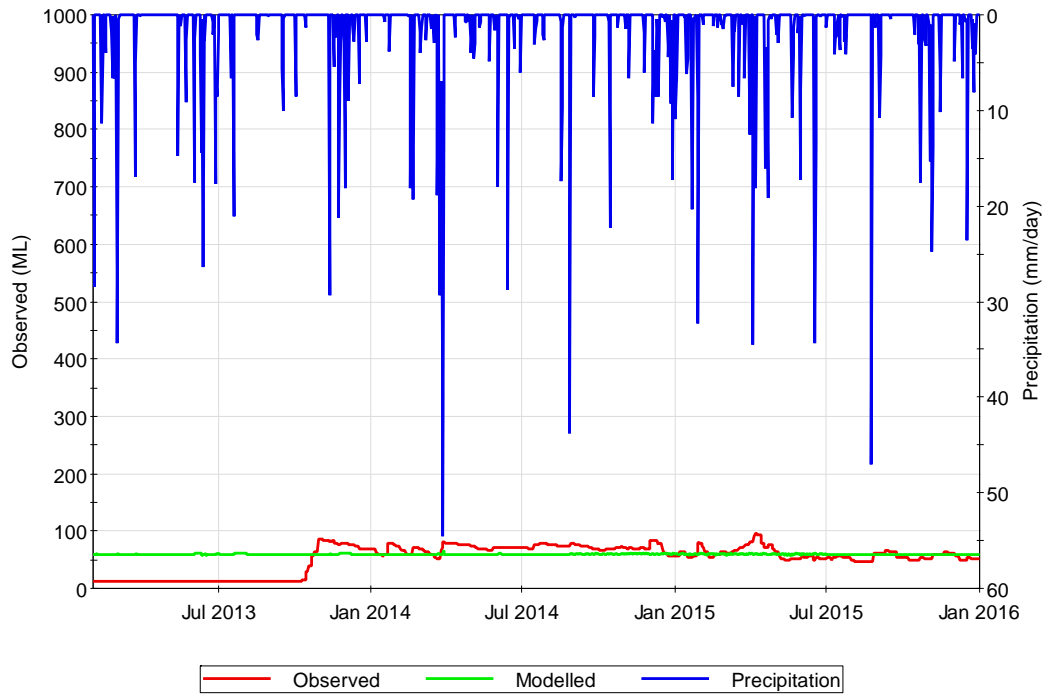

Figure 5-5 Observed and modelled SD10 storage volume

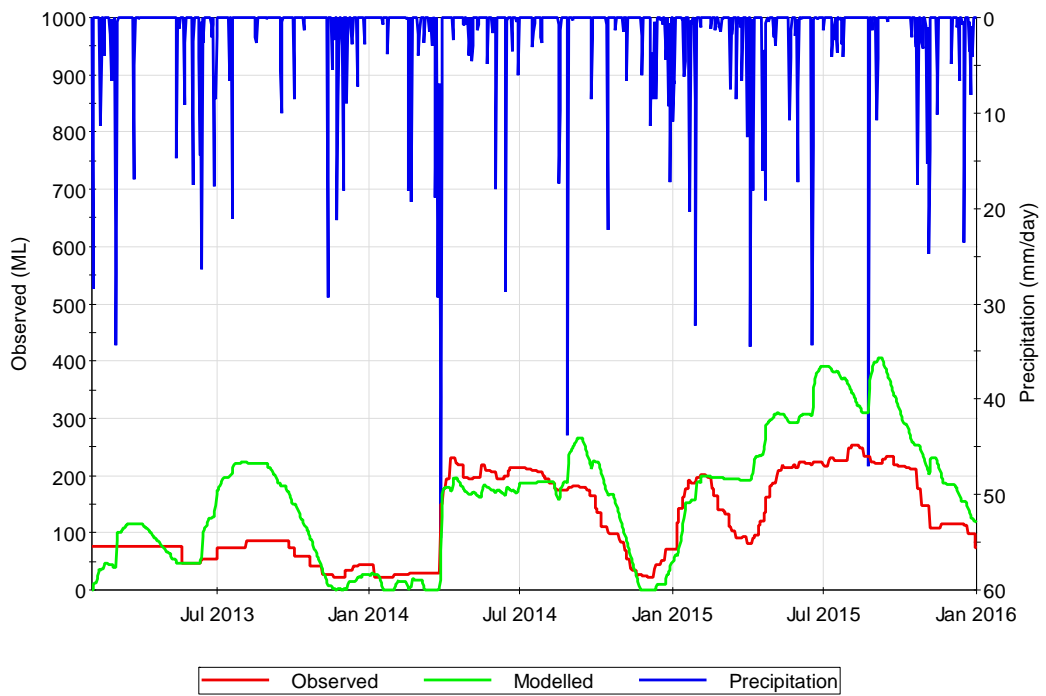

Figure 5-6 Observed and modelled Strip #9 water storage volume

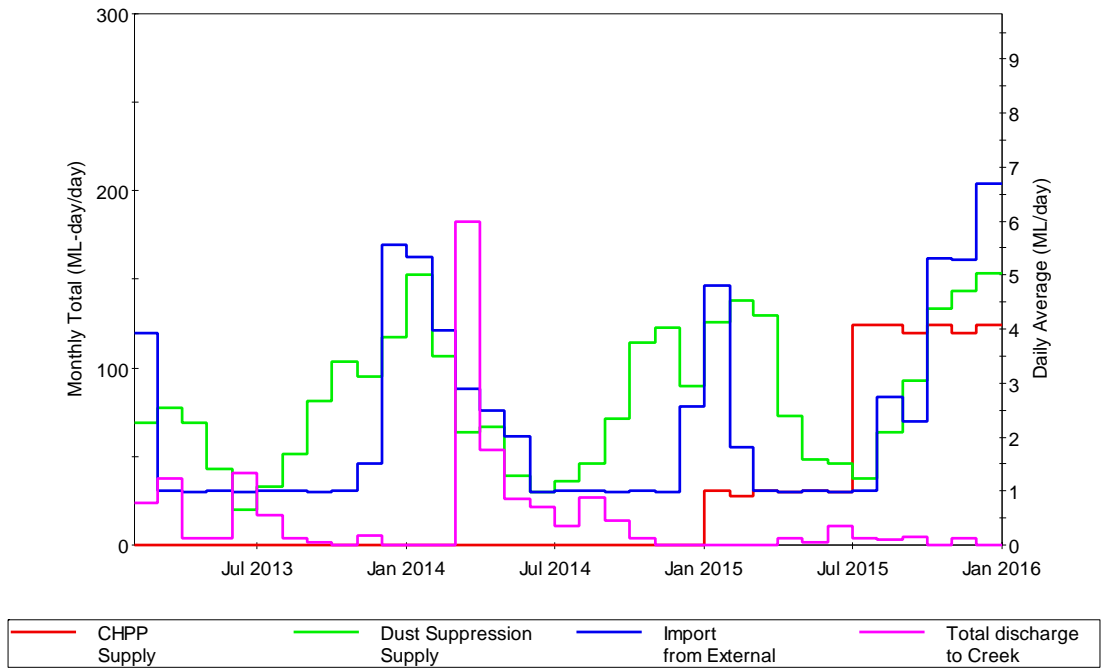

Figure 5-7 Modelled monthly usage and supply

Overall, the modelled total storage volume has higher runoff driven peaks than the observed data, which considered on its own, would indicate that the adopted runoff parameters may be overestimating runoff. This is likely due to the model simulating immediate and complete dewatering of sediment basins whereas, in reality, practical requirements may have delayed and attenuated this dewatering. Therefore, the comparison of total annual volumes is a more appropriate indicator of model performance for this purpose of this validation.

The observed and modelled usage and supply are summarised in Table 5-3.

Table 5-3 Validation of annual totals

Year	Observed (ML)	Modelled (ML)	Relative error
Total CHPP usage			
2013	0	0	
2014	0	0	
2015	910	910	0 %
Haul road dust suppression			
2013	699	760	9 %
2014	1016	939	-8 %
2015	1176	1184	1 %
Total imported water (including MIA and potable bore)			
2013	678	581	-14 %
2014	843	771	-9 %
2015	792	1036	31 %
Total	2313	2388	3 %
Discharge			
2013		134	
2014		273	
2015		42	

The perfect fit for CHPP usage is expected, as constant demand was applied that was equal to the estimated actual usage. The modelled haul road dust suppression achieved a satisfactory fit to the observed annual totals.

The discharge volumes are unable to be validated as accurate since estimates of discharge volumes are unable to be made. However, as discharge only occurs during high rainfall periods when the storage capacity of BCM has already been exceeded this is unlikely to have a significant impact of the overall results.

The acceptable fit for river extractions for each individual year, in addition to the close fit for the total over calibration period, indicates that the SWB model is accurately representing the overall site water balance over the calibration period.

The results of the validation suggest that the revised SWB model is satisfactorily reflecting site conditions from period from 2013 to 2015.

6. Site water balance model results

The water balance model, described in Section 4, was used to simulated the water management system over the life of the Boggabri Coal Mine (from 2017 to 2033). The simulation was repeated 127 times using simulated climatic conditions sampled from the historical record (see Section 2.2). The results of the simulation were statistically summarised.

6.1 Overall site water balance

The median annual site water balance is provided in Table 6-1 for the existing, 2018, 2022 and 2033 'snapshot' year landforms.

Table 6-1 Median site water balance for each of the snapshot years

	Existing	2018	2022	2033
Inflows (ML)				
Runoff and direct rainfall:				
▪ Clean water (highwall) dams	-	-	-	58
▪ Dirty water sediment dams	321	481	1147	1131
▪ Contaminated water dams, MWDs and pit	1050	1040	697	791
Groundwater make	213	269	334	266
Imported water from borefield	357	2081	2081	1763
Import water from Namoi River	1421	0	0	0
Total Inflows (ML)	3363	3871	4259	4008
Outflows (ML)	0			
Demands	0			
▪ Dust suppression - haul roads	1374	1374	1374	1374
▪ CHPP	1460	1460	1460	1460
▪ MIA and potable water	364	365	365	365
Evaporation:	0			
▪ Clean water (highwall) dams	-	-	-	23
▪ Dirty water sediment dams	91	95	119	206
▪ Contaminated water dams, MWDs and pit	224	345	327	336
Site wide release to Nagero Creek				
▪ Clean water (highwall dam) controlled discharge to creek	-	-	-	37
▪ Dirty water sediment dam overflows to creek	0	0	62	0
▪ Dirty water sediment dam controlled discharge to creek	133	115	717	138
Total Outflows (ML)	3646	3754	4425	3940
Change in storage (ML)	-287	117	-88	5

Due the intertwining of the different natural and operational processes in the SWB model, the median values of the different inflows and outflows do not coincide. Therefore, unlike mean values, the median of the total inflows and total outflows do not necessarily balance. Nonetheless, median values have been shown as they are a more representative measure of central tendency for processes with skewed distribution, such as rainfall.

Median dust suppression usage is less than 1416 ML/year as dust suppression is modelled to occur only on days with total daily rainfall depth is less than 5 mm (refer to Section 4.6.1).

6.2 Imported water requirements

A summary of the simulated water imported to site over the life of the Mine is provided in Figure 6.2 and a summary table for the snapshot years is provided in Table 6-2. Note that the values in Figure 6.2 and Table 6-2 are not limited by the existing entitlements held by BCOPL.

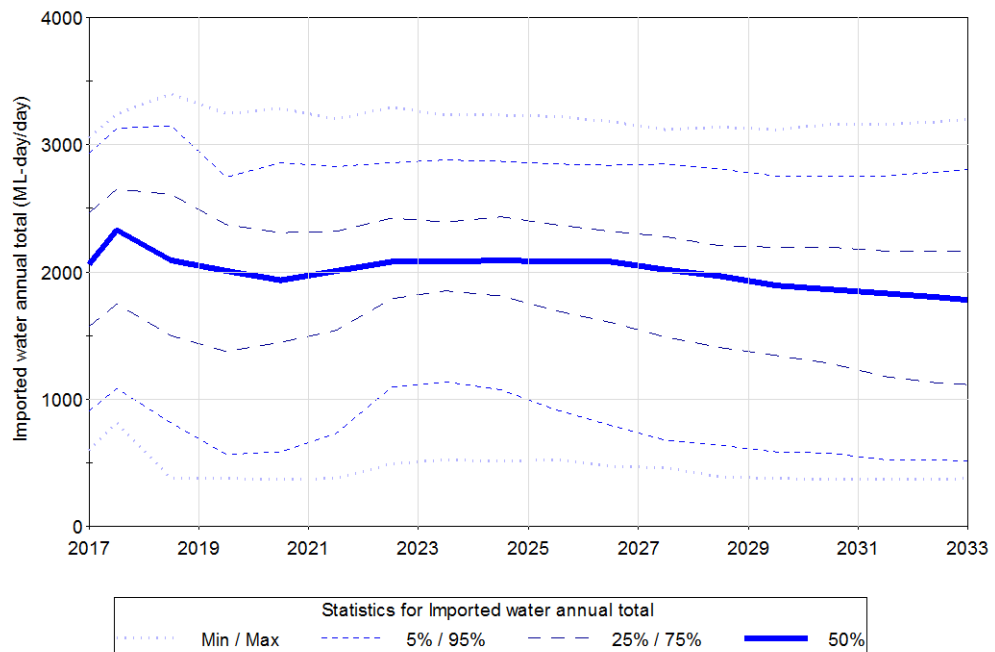

Figure 6.1 Simulated time series of annual water imported to site

Table 6-2 Annual totals of imported water requirements

	Annual total (ML)			
	Existing	2018	2022	2033
5th percentile (wet)	723	809	1094	511
25th percentile	1385	1496	1792	1091
50th percentile (median)	1781	2088	2081	1763
75th percentile	2262	2604	2420	2164
95th percentile (dry)	2718	3143	2854	2823
Greatest result (driest on record)	2862	3393	3295	3216

Supplementary water will be imported to the BCM to meet dust suppression and CHPP process water demands. Even when the BCM is in a contaminated water surplus, high-quality imported water is required to meet the potable water and vehicle wash-down demands. The maximum modelled daily pump rate of imported water to the BCM was approximately 9.4 ML/day. The daily average pump rate is higher than the daily demand of 9.0 ML/day as it accounts for evaporation losses of imported water stored in SD10 and MW2 / MW5.

A total of 1028 unit shares of groundwater will be available to BCOPL from the existing Zone 4 Water Groundwater Source water access licences. The actual volume of groundwater available will depend on the Available Water Determination made under the relevant Water Sharing Plan. This entitlement does not include 842 unit shares of groundwater available to BCOPL from the existing Gunnedah Oxley Basin Groundwater Source aquifer licence. . Assuming an allocation of 1 ML per unit share, it can be expected that approximately 1870 ML/year be available to BCOPL from the existing water access licences.

BCOPL is able to access surface water from the Namoi River in accordance with its surface water licences via a pump station on the Namoi River. Assuming an allocation of 1 ML per unit share, BCOPL holds a total of 422 unit shares of general security surface water entitlements and an additional 32.2 unit shares which would be available to BCOPL from the Namoi River.

Under the existing water licences, a maximum of 2324 ML (the actual volume is dependent on annual Available Water Determinations) is available for the supply of water to BCM. Groundwater can be traded on a temporary or permanent basis within the greater Gunnedah-Oxley Basin Groundwater Source, and within Zone 4 of the Upper Namoi Valley (Keepit Dam to Gins Leap) Ground Water Source. BCOPL will source additional water by trading water, either temporarily or permanently so sufficient water is available for the operations at BCM.

6.3 Contaminated water storage and pit availability

Water balance modelling indicates that no overflows from mine water dams MW2 / MW5 and MW3 or contaminated water dams SD10, SD11, SD12, SD28 and SD29 are expected over the life of BCM.

Summaries of the simulated daily time series of water stored in the mining void, Strips #9, MW2, MW3 and MW5 over the life of BCM are provided in Figure 6.2, Figure 6.3, and Figure 6.4, respectively. Note that the percentiles shown in the daily time series plots are daily percentile ranks of the daily results, whereas the percentile shown in Table 6-1, and Figure 6.1 are percentile ranks of the annual results.

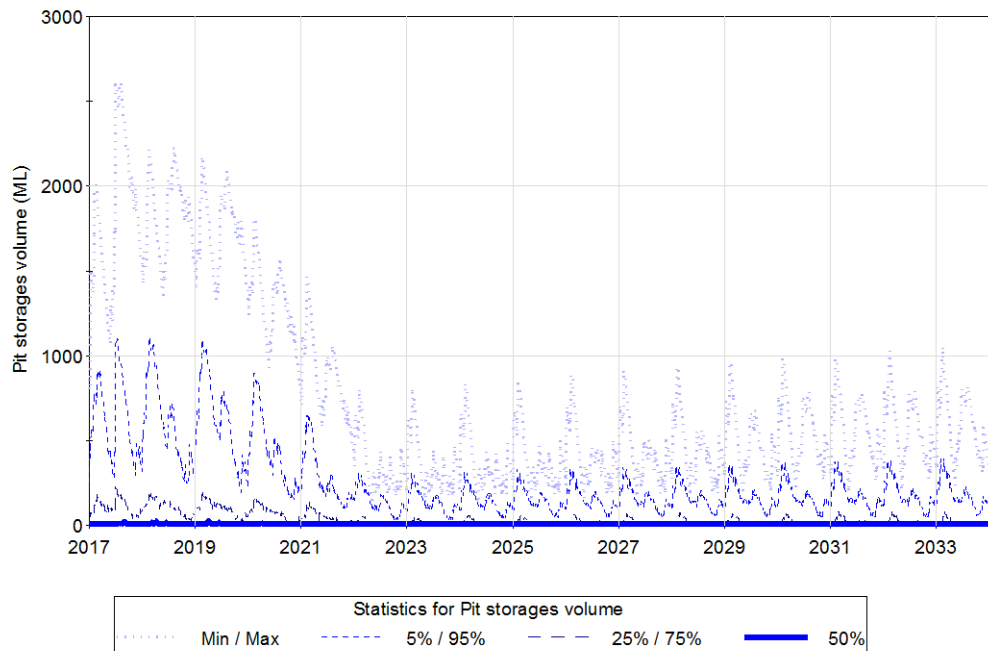

Figure 6.2 Simulated time series of water stored in-pit sumps

Figure 6.2 shows that the pit void is predicted to empty most of the time, however the volume stored at any one time may reach approximately 2000 ML. This maximum volume may reduce following 2023 as the catchment area reporting to the pit void is reduced.

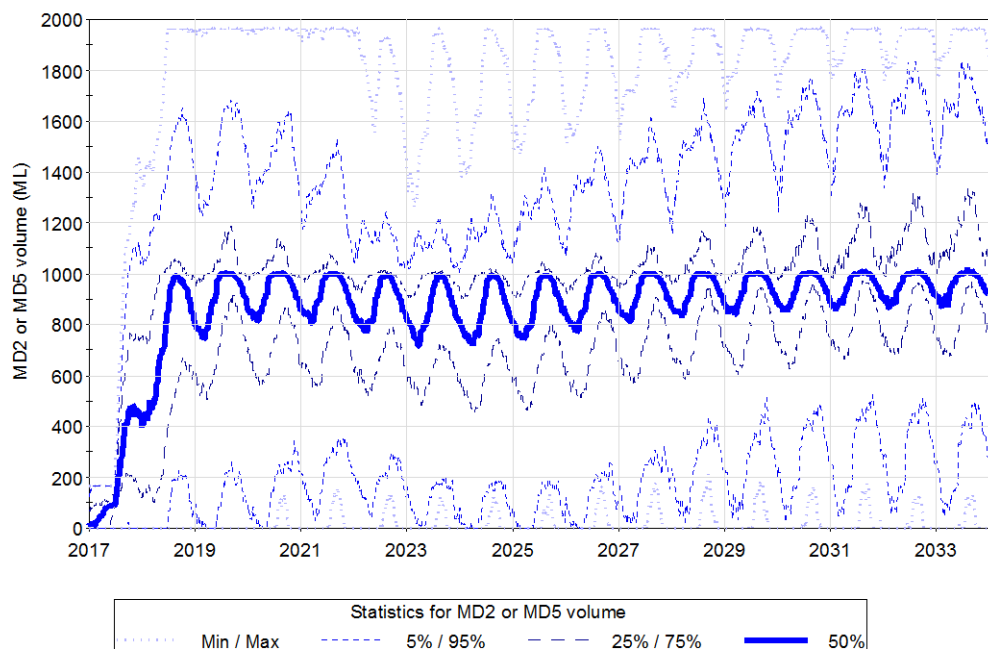

Figure 6.3 Simulated time series of water stored in MW2 / MW5

Figure 6.3 shows that the volume stored in MW5, after is construction, is predicted to most likely remain close the assumed normal operating volume of 1000 ML, but may increase to the high operating volume or empty.

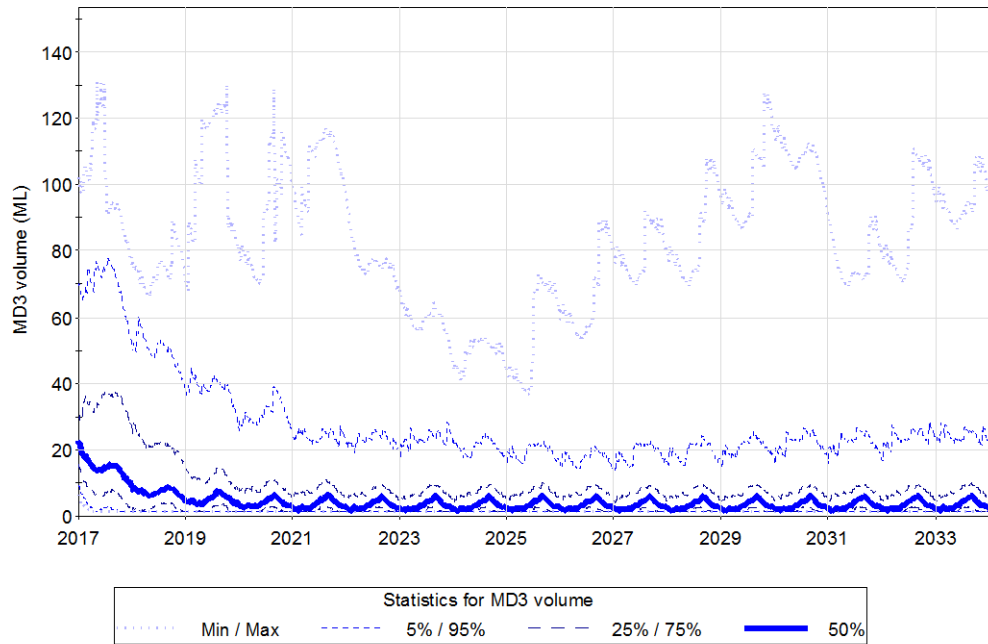

Figure 6.4 Simulated time series of water stored in MW3

Figure 6.4 shows that the volume stored in MW3 is predicted to remain relatively low, but may reach volumes at to approximately 130 ML. This reflects the assumed operating rules whereby MW3 is used as additional dewatering capacity for SD10 after MW2/MW5 reach their high operating volume.

7. Water efficiency initiatives

The action plan and schedule to implement water efficiency initiatives and the recommendations (Advisian, 2016) referenced in appendix 6A of the Project Approval are provided in Table 7.1.

Table 7.1 Water Balance Initiatives Action Plan

BCOPL Water Efficiency Initiatives	
Action Plan	Schedule
Propose water efficiency initiatives during the SWB annual review process.	Annually during the SWB annual review process
Report on the effectiveness of water efficiency initiatives.	Annually in the AEMR
Water Efficiency Initiatives Project Approval Appendix 6A	
Action Plan	Schedule
1. Install meters for all major water flows including:	
<ul style="list-style-type: none"> • Water transfers from sediment dams and mine pits into mine water storages. 	By end 2017
<ul style="list-style-type: none"> • All water-cart fill points. 	By end 2017
<ul style="list-style-type: none"> • All elements of the anticipated water demands for various purposes associated with CHPP (as identified in Table 4 of the letters dated 8 July) 	By end 2017
<ul style="list-style-type: none"> • All water imports including any bore water obtained onsite. 	Within one week of commencing operation.
2. Install water level meters on all significant water storage as a check on inflows and outflows and a means of assessing evaporation and seepage losses. This data will also provide a basis for improving estimates of the runoff from different surface types (hardstand, mine pit, "raw" overburden)	By end of June 2018
3. Collect moisture content data for all coal flows associated with the CHPP to permit full water balance accounting	By end 2017
4. Record all flow meters and water levels at least weekly (preferable by means for continuous recording) and analyse the data on a monthly basis to develop a full accounting of all water sources and losses.	Within one month of flow meters and water level instruments being installed.
5. Compare monitored gains from rainfall and losses by evaporation from water storages to the rainfall and evaporation data from the weather station.	By end 2017
6. Update the site water balance annually bases on monitored data and provide details in the annual report to	Annual SWB revision as outlined in Section 8.3

the Department.	
-----------------	--

8. Improvement and reporting

8.1 Annual Improvement Program

BCOPL will undertake an annual improvement program to identify and address deficiencies and improvements within monitoring, measurement and calculation methods presented in the SWB. The improvement program will include a review of the monitoring, measurements and calculation methods used in the SWB and where required outline any improvements to address deficiencies in these. The results of the improvement program will be incorporated into the annual revision of the SWB presented as part of the Annual Review required under Schedule 5, condition 4 of the Project Approval. .

8.2 Validation Program

BCOPL will perform a validation of the SWB model on an annual basis. The existing model will be used to simulate the water management system for the previous year using observed site rainfall. The observed borefield extraction, river water extraction, CHPP usage, dust suppression usage, potable/washdown usage, catchment areas, discharge events and storage volumes (in SD10, MW2, MW3, MW5, Strip #9 and in-pit) will be compared to modelled results on a monthly basis.

As the BCM is predicted to be in water deficit under most climatic conditions and the contaminated water system is designed to contain and manage the 100 year ARI 72 hour rainfall event, discharges from the BCM are expected to be only from sediment dams following significant rainfall events. Therefore, the discharge volumes from the BCM may be estimated and validated using observations of the incidence of discharge events.

If the SWB model is found to not be realistically representative of the management system, an investigation will be undertaken that may involve a calibration process, similar to that described in Section 5, to identify the source of the discrepancy. The updated SWB model will be used to update predictions described in Section 6.

A summary of the validation will be incorporated into the annual revision of the SWB presented as part of the Annual Review.

8.3 Annual Review

The Annual Review summarises the environmental performance of the mine for the previous calendar year. In accordance with Schedule 5, condition 4 of the Project Approval, the relevant monitoring data will be used to revise the SWB annually and will be provided in the Annual Review.

The Annual Review will be made publically available on the Boggabri Coal Mine website [Idemitsu Approvals, Plans & Reports - Idemitsu](#).

9. Review and revision

9.1 Review

Review of the SWB will be undertaken by BCOPL in accordance schedule 5 condition 5 of the Project Approval within 3 months of the submitting the following:

- Annual Review under condition 4 of the Project Approval.
- incident report under condition 8 of the Project Approval.
- audit under condition 10 of the Project Approval.
- a modification to the Project Approval.

Where this review results in revisions to the SWB, then within 4 weeks of the completion of the revision, unless the Secretary agrees otherwise, the revised document will be submitted to the Secretary for approval.

10. References

Australasian Groundwater & Environmental Consultants (AGE), October 2010. Continuation of Boggabri Coal Mine Project Groundwater Water Assessment.

Boggabri Coal Pty Limited (BCPL), March 2012. Mine Water Balance Review – Boggabri Coal Project.

Department of Environment, Climate Change and Water (DECCW), 2008. Managing Urban Stormwater - Soils and Construction - Volume 2E Mines and Quarries.

Smith M, 1998. Crop evapotranspiration: Guidelines for computing crop water requirements. Food and Agriculture Organization of the United Nations. Irrigation and Drainage paper No. 56.

Hansen Bailey, December 2010. Continuation of Boggabri Coal Mine Environmental Assessment.

Hansen Bailey, August 2011. Boggabri Coal Mine Environmental Assessment - Modification to Development Consent.

DECCW, 2008. *Managing Urban Stormwater - Soils and Construction - Volume 2E Mines and Quarries*. New South Wales Government.

Ladson, A., 2008. *Hydrology: An Australian Introduction*. Oxford University Press: Melbourne.

Morton, 1983. Operational estimates of areal evapotranspiration and their significance to the science and practice of hydrology. *Journal of Hydrology*, Volume 66, 1-77.

Parsons Brinckerhoff (PB), October 2010. Continuation of Boggabri Coal Mine Project Surface Water Assessment.

Parsons Brinckerhoff (PB), 2009. Boggabri Coal Mine 2008 Site Water Balance.

Parsons Brinckerhoff (PB), 28 August 2015. Boggabri Coal Mine – Drawdown Impact Assessment of Proposed Borefield Operations (2200555A_WAT_REP_Borefield assessment_RevC)

Ribbons C, 2009. Water availability in New South Wales Murray–Darling Basin regulated rivers, NSW Department of Water and Energy, Sydney.

Stephen J. Jeffrey, John O. Carter, Keith B. Moodie, Alan R. Beswick, Using spatial interpolation to construct a comprehensive archive of Australian climate data, *Environmental Modelling & Software*, Volume 16, Issue 4, June 2001, Pages 309-330, ISSN 1364-8152, [http://dx.doi.org/10.1016/S1364-8152\(01\)00008-1](http://dx.doi.org/10.1016/S1364-8152(01)00008-1).

Appendix A

Summary of methodologies

Table A.1 Summary of methodology

Process	Data source	Measurement type	Relevant formulas
Mass balance	NA	Mass conservation	Refer to Section 4.1
Staging of storages	Life-of-Mine plans	Assumed	Refer to Section 4.3
Historical rainfall	SILO Data Drill	Interpolated from observed rainfall gauges	Refer to Stephen et al. (2001) and Section 2.2
Historical potential evapotranspiration depth	SILO Data Drill	Interpolated from observed data	Refer to Smith (1998) and Section 2.2
Historical potential open water evaporation depth	SILO Data Drill	Interpolated from observed data	Refer to Morton (1983) and Section 2.2
Future climatic conditions	SILO Data Drill	Sampled concurrently from historical record	Refer to Section 2.2
Existing catchment and landuse areas	LiDAR and aerial imagery	Measured	Refer to Section 4.4.2 and Appendix B
Future catchment and landuse areas	Life-of-Mine plans	Measured	Refer to Section 4.4.2 and Appendix B
Catchment runoff	NA	Estimated using AWBM with validated parameters	Refer to Section 2.4, Section 4.5.1 and Section 5
Existing storage capacity	BCOPL	As constructed	Refer to Section 4.4.1
Storage maximum surface area and geometry	LiDAR and aerial imagery	Measured	Refer to Section 4.4.1
MW2 stage storage relationship	BCOPL	Measured by survey	Refer to Section 4.4.1 and Appendix D
Storage water surface area	NA	Calculated from stage storage relationships or approximated geometry	Refer to Section 4.4.1
Direct rainfall	NA	Calculated from modelled rainfall and water surface area	Refer to Section 4.5.1
Actual evaporation losses	NA	Calculated from modelled evaporation and surface area	Refer to Section 4.7.1
Groundwater inflows	Groundwater model predictions	Calculated	Refer to AGE (2010) and Section 4.5.2
Past CHPP usage	BCOPL	Estimated from site experience	Refer to Section 4.6.2 and Section 5
Past dust suppression usage	BCOPL	Measured as monthly totals	Refer to Section 5
Past potable and washdown usage	BCOPL	Estimated from site experience	Refer to Section 4.6.3 and Section 5
Future CHPP usage	BCOPL	Estimated from site experience	Refer to Section 4.6.2
Future dust suppression usage	BCOPL	Estimated from site experience	Refer to Section 4.6.1
Future potable and washdown usage	BCOPL	Estimated from site experience	Refer to Section 4.6.3
Site operating rules	BCOPL	Idealised from actual site management	Refer to Section 4.4.3 and Section 4.5.3
Off-site releases	NA	Calculated from mass balance	Refer to Section 4.7.3

Appendix B

Water management system plans
and schematics

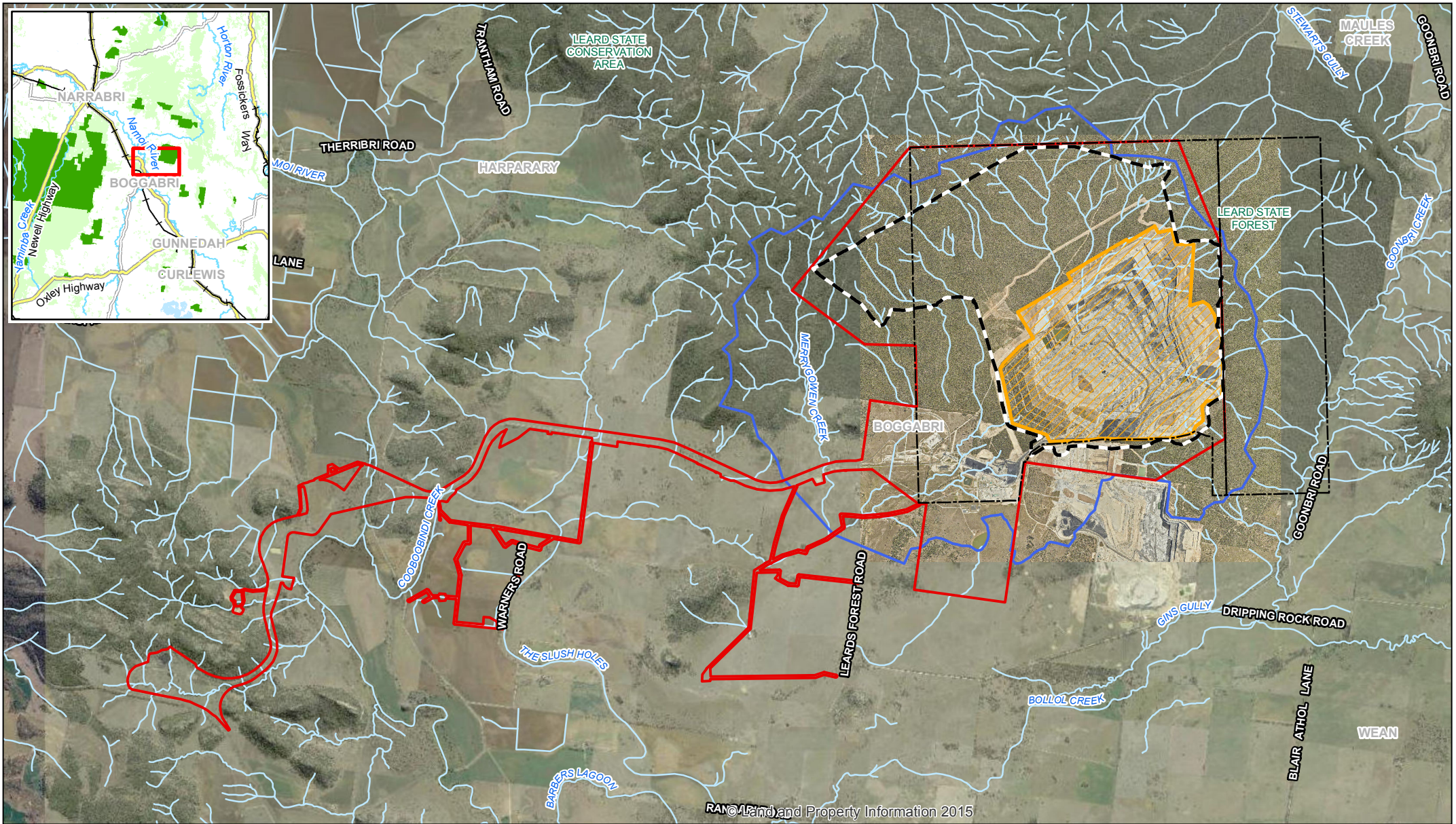

RAN Land and Property Information 2015

Paper Size A4
 0 625 1,250 1,875 2,500
 Metres
 Map Projection: Transverse Mercator
 Horizontal Datum: GDA 1994
 Grid: GDA 1994 MGA Zone 56

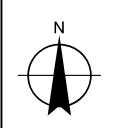

- LEGEND**
- Mine disturbance area
 - Federal approval limit
 - Project approval area
 - Mine tenement
 - Study catchment



Boggabri Coal Operations Pty Ltd
 Boggabri Coal Site Water Balance

Job Number 22-18361
 Revision 0
 Date 19 Jan 2017

Locality plan

Figure B-1

G:\2218361\GIS\Maps\Deliverables\SiteWaterBalance\2218361_SWB001_Locality_0.mxd Level 3, GHD Tower, 24 Honeysuckle Drive, Newcastle NSW 2300 T 61 2 4979 9999 F 61 2 4979 9988 E ntmail@ghd.com W www.ghd.com.au
 © 2017. Whilst every care has been taken to prepare this map, GHD, Geoscience Australia, LPI and BCOPL make no representations or warranties about its accuracy, reliability, completeness or suitability for any particular purpose and cannot accept liability and responsibility of any kind (whether in contract, tort or otherwise) for any expenses, losses, damages and/or costs (including indirect or consequential damage) which are or may be incurred by any party as a result of the map being inaccurate, incomplete or unsuitable in any way and for any reason.
 Data source: Geoscience Australia: 250k Topographic Data Series 3, 2006; LPI: DTDB / DCDB, 2012, Aerial Imagery, 2016; BCOPL: Mining boundaries, 2016. Created by: fmacKay

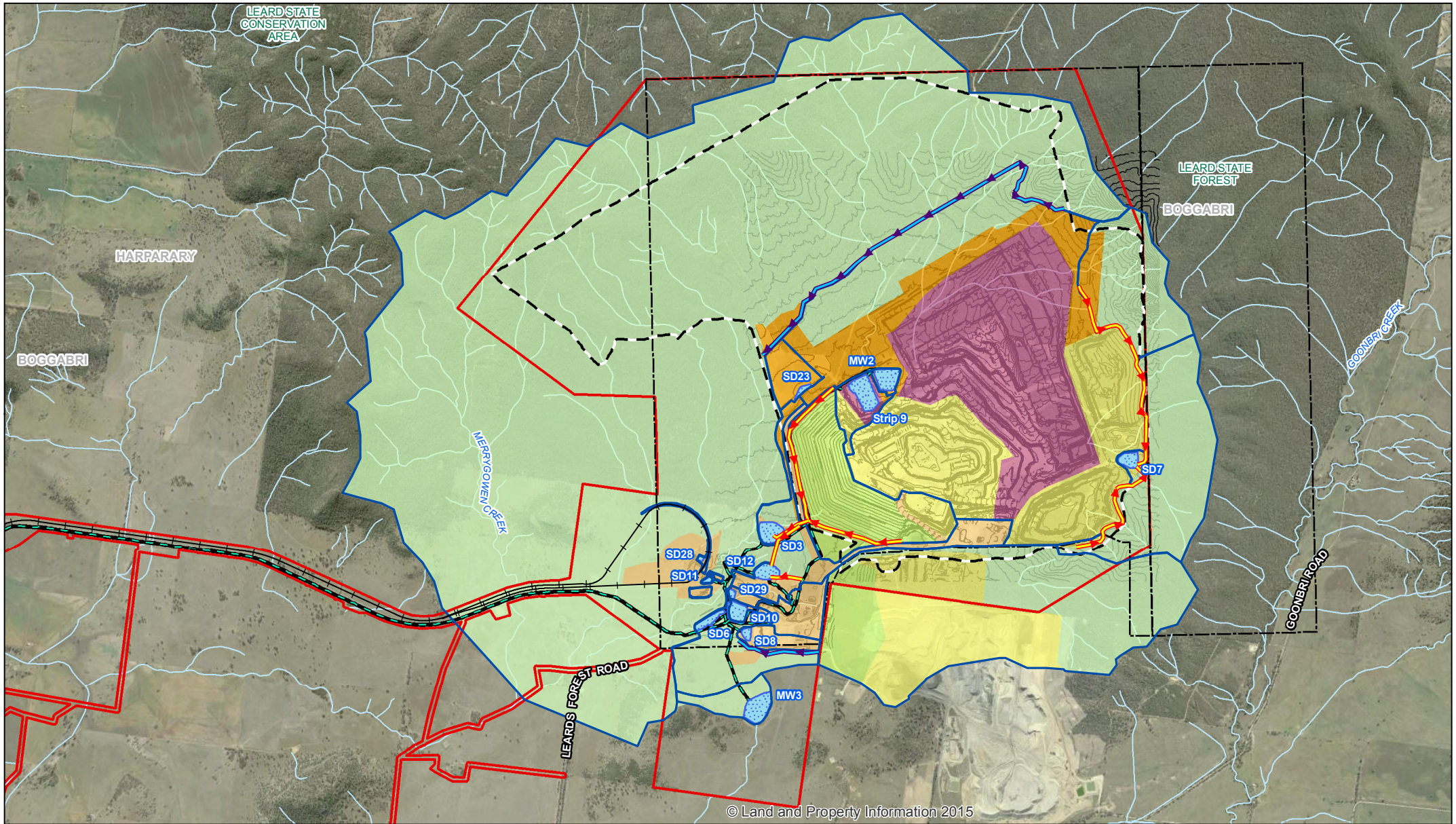

© Land and Property Information 2015

Paper Size A4
 0 375 750 1,125 1,500
 Metres
 Map Projection: Transverse Mercator
 Horizontal Datum: GDA 1994
 Grid: GDA 1994 MGA Zone 56

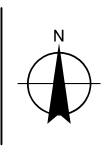

LEGEND

- | | | |
|------------------------|-------------------------|---------------------|
| Federal approval limit | Water balance catchment | Undisturbed |
| Project approval area | Clean water drain | Cleared |
| Mine tenement | Dirty water drain | Mining void |
| Rail loop | Pump pipeline | Unshaped spoil dump |
| Water storage | Contour | Rehabilitation |
| | | Road / industrial |



Boggabri Coal Operations Pty Ltd
 Boggabri Coal Site Water Balance

Job Number 22-18361
 Revision 0
 Date 19 Jan 2017

**Water management system
 Existing layout**

Figure B-2

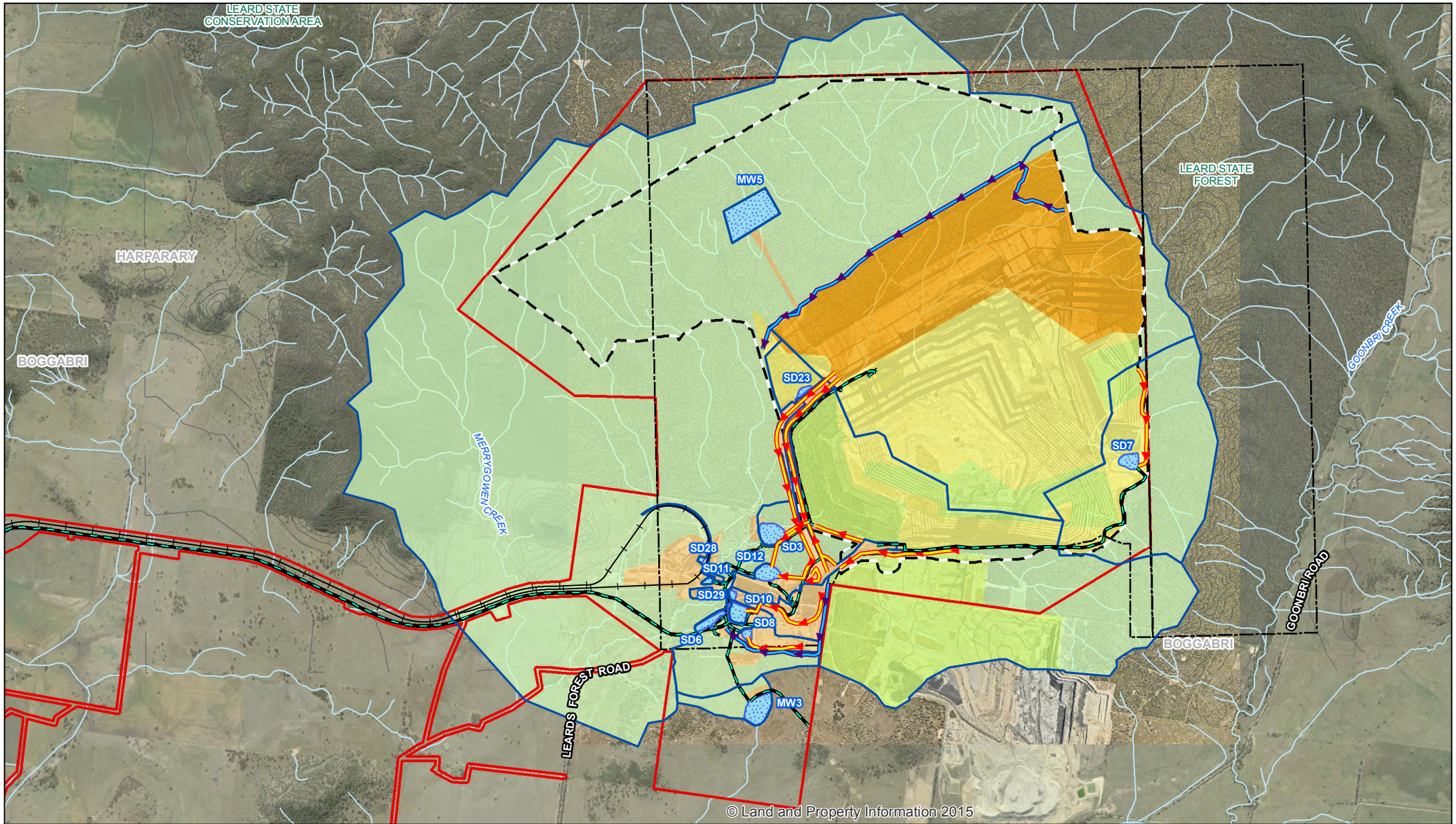

© Land and Property Information 2015

Paper Size A4
 0 375 750 1,125 1,500
 Metres
 Map Projection: Transverse Mercator
 Horizontal Datum: GDA 1994
 Grid: GDA 1994 MGA Zone 56

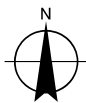

LEGEND

- | | | | |
|------------------------|-------------------------|---------------------|-------------------|
| Federal approval limit | Water balance catchment | Undisturbed | Road / industrial |
| Project approval area | Clean water drain | Cleared | Mining void |
| Mine tenement | Dirty water drain | Unshaped spoil dump | Rehabilitation |
| Rail loop | Pump pipeline | Water storage | Contour |



Boggabri Coal Operations Pty Ltd
 Boggabri Coal Site Water Balance

Job Number 22-18361
 Revision 0
 Date 19 Jan 2017

**Water management system
 Indicative layout (2018)**

Figure B-3

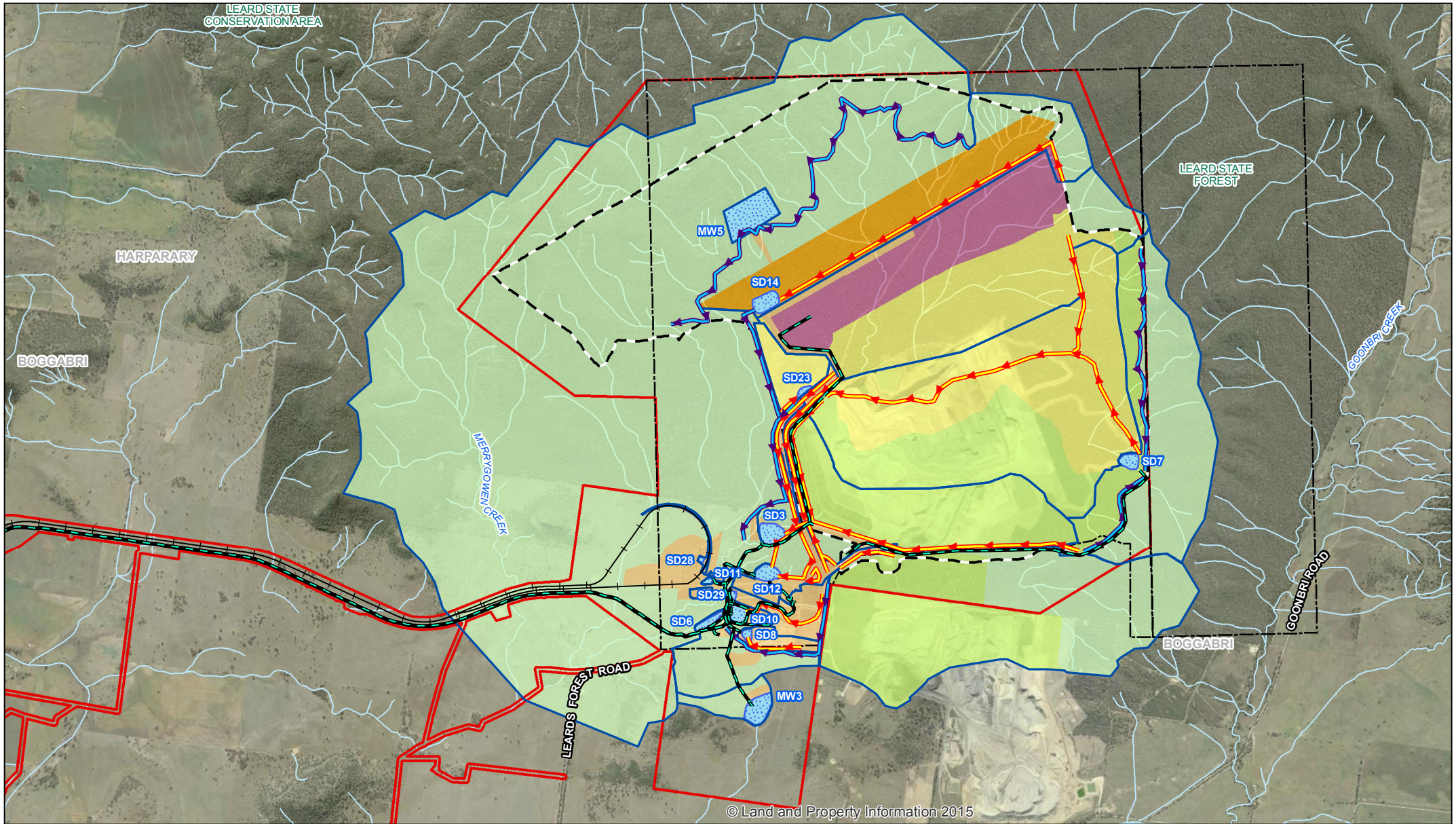

© Land and Property Information 2015

Paper Size A4
 0 375 750 1,125 1,500
 Metres
 Map Projection: Transverse Mercator
 Horizontal Datum: GDA 1994
 Grid: GDA 1994 MGA Zone 56

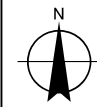

LEGEND

- | | | | |
|------------------------|-------------------------|---------------------|-------------------|
| Federal approval limit | Water balance catchment | Undisturbed | Road / industrial |
| Project approval area | Clean water drain | Cleared | Mining void |
| Mine tenement | Dirty water drain | Unshaped spoil dump | Rehabilitation |
| Rail loop | Pump pipeline | | |
| Water storage | | | |



Boggabri Coal Operations Pty Ltd
 Boggabri Coal Site Water Balance

Job Number 22-18361
 Revision 0
 Date 19 Jan 2017

Water management system
 Indicative layout (2022)

Figure B-4

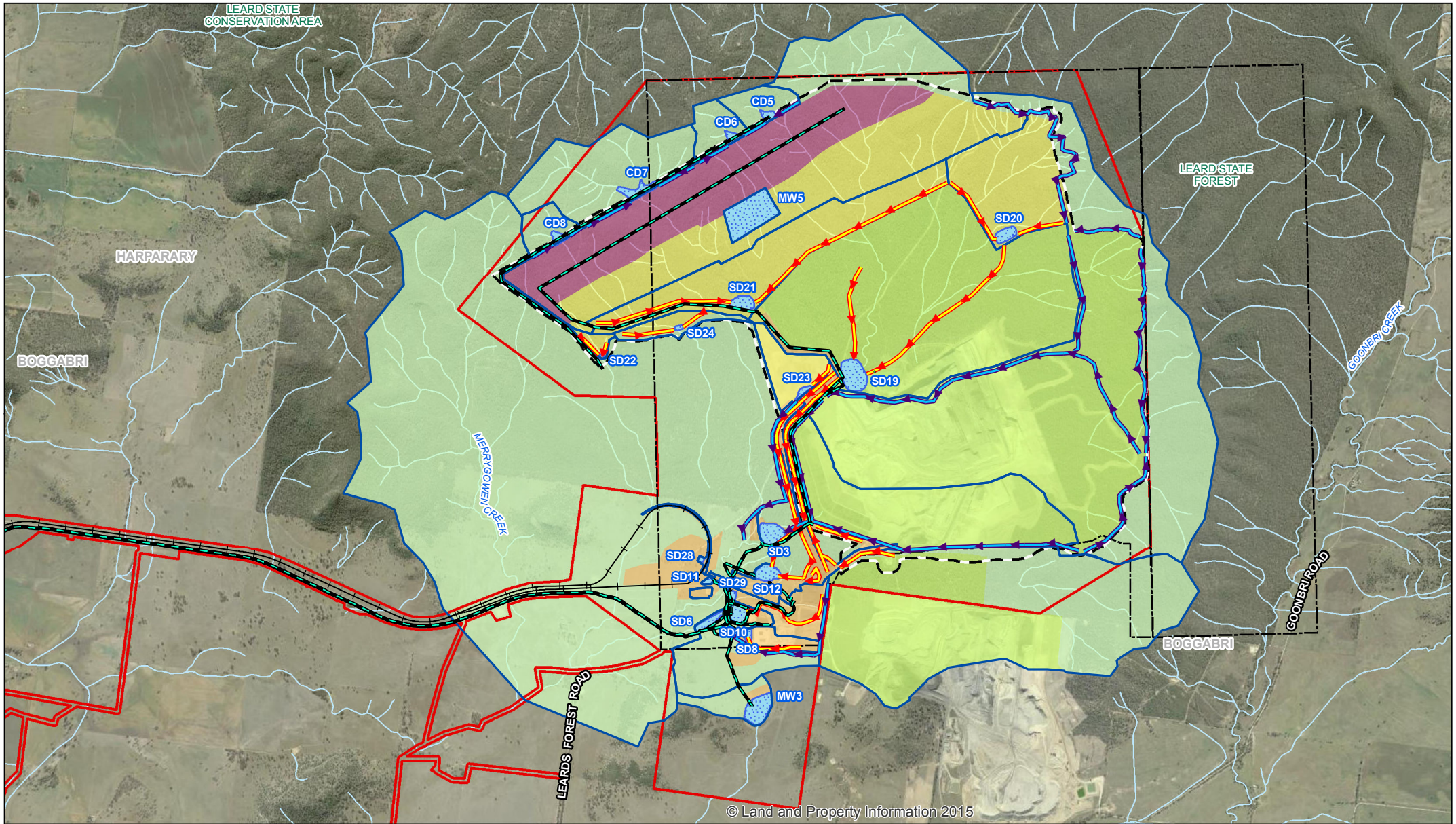

© Land and Property Information 2015

Paper Size A4
 0 375 750 1,125 1,500
 Metres
 Map Projection: Transverse Mercator
 Horizontal Datum: GDA 1994
 Grid: GDA 1994 MGA Zone 56

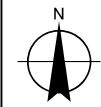

LEGEND

- | | | |
|------------------------|-------------------------|---------------------|
| Federal approval limit | Water balance catchment | Undisturbed |
| Project approval area | Clean water drain | Mining void |
| Mine tenement | Dirty water drain | Unshaped spoil dump |
| Rail loop | Pump pipeline | Rehabilitation |
| Water storage | Road / industrial | |



Boggabri Coal Operations Pty Ltd
 Boggabri Coal Site Water Balance

Job Number 22-18361
 Revision 0
 Date 19 Jan 2017

Water management system
 Indicative layout (2033)

Figure B-5

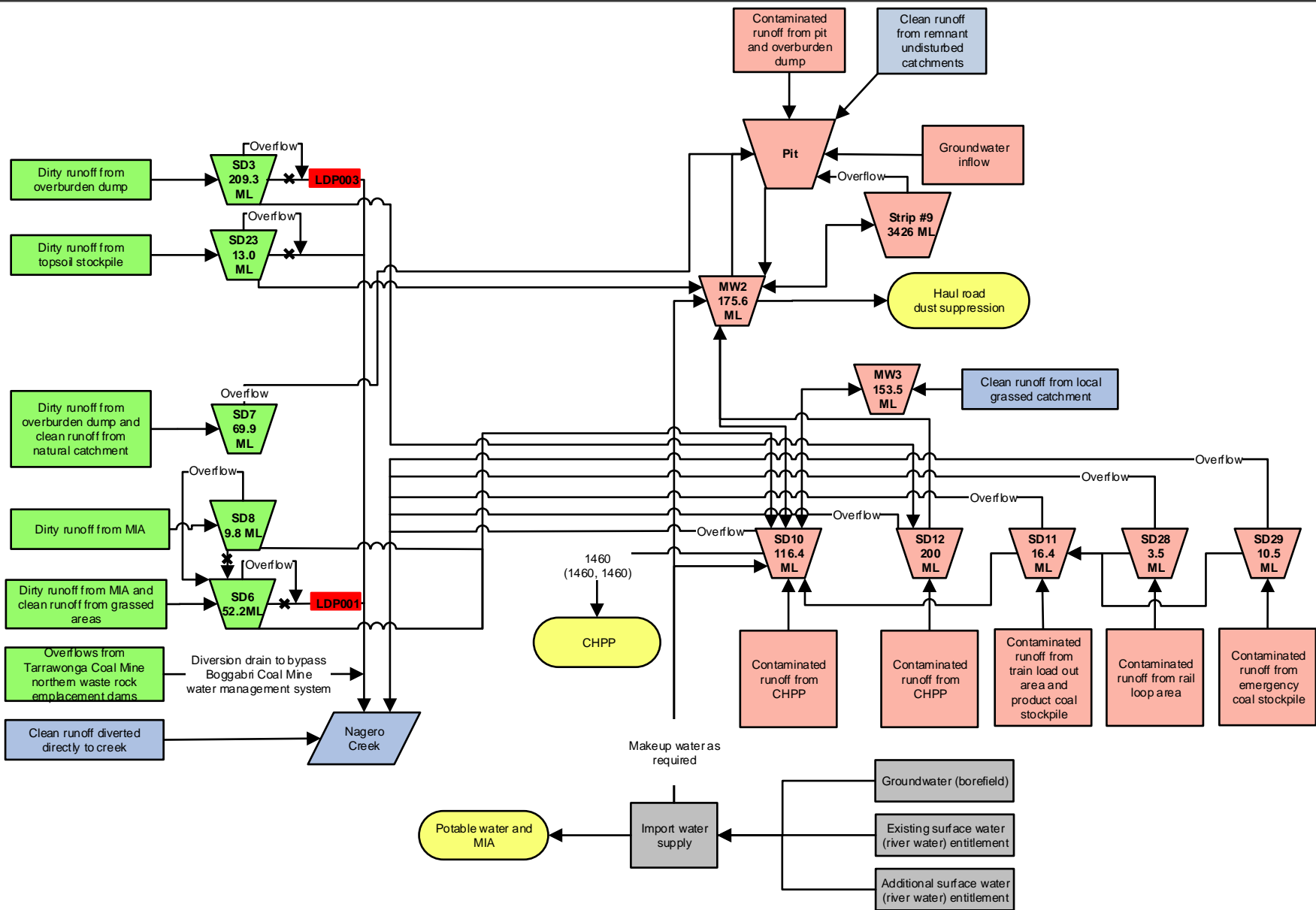

LEGEND	
	Surface Water Transfer
	Storage
	Manually operated valve
	Median (ML/year)
	10 th , 90 th percentile
	Import water system
	Dirty water system
	Contaminated water system
	Clean water system
	Usage

© 2017. Whilst every care has been taken to prepare this figure, GHD make no representations or warranties about its accuracy, reliability, completeness or suitability for any particular purpose and cannot accept liability and responsibility of any kind (whether in contract, tort or otherwise) for any expenses, losses, damages and/or costs (including indirect or consequential damage) which are or may be incurred by any party as a result of the figure being inaccurate, incomplete or unsuitable in anyway and for any reason.

LOCATION	BCM
DRAWN	TT
CHECKED	AW
APPROVED	SG
SCALE	NTS

Boggabri Coal Operations Pty Ltd
 Boggabri Coal Mine
 Site Water Balance
 Water balance model schematic
 Existing conditions

DATE 5 May 2017	Figure B-6
-----------------	------------

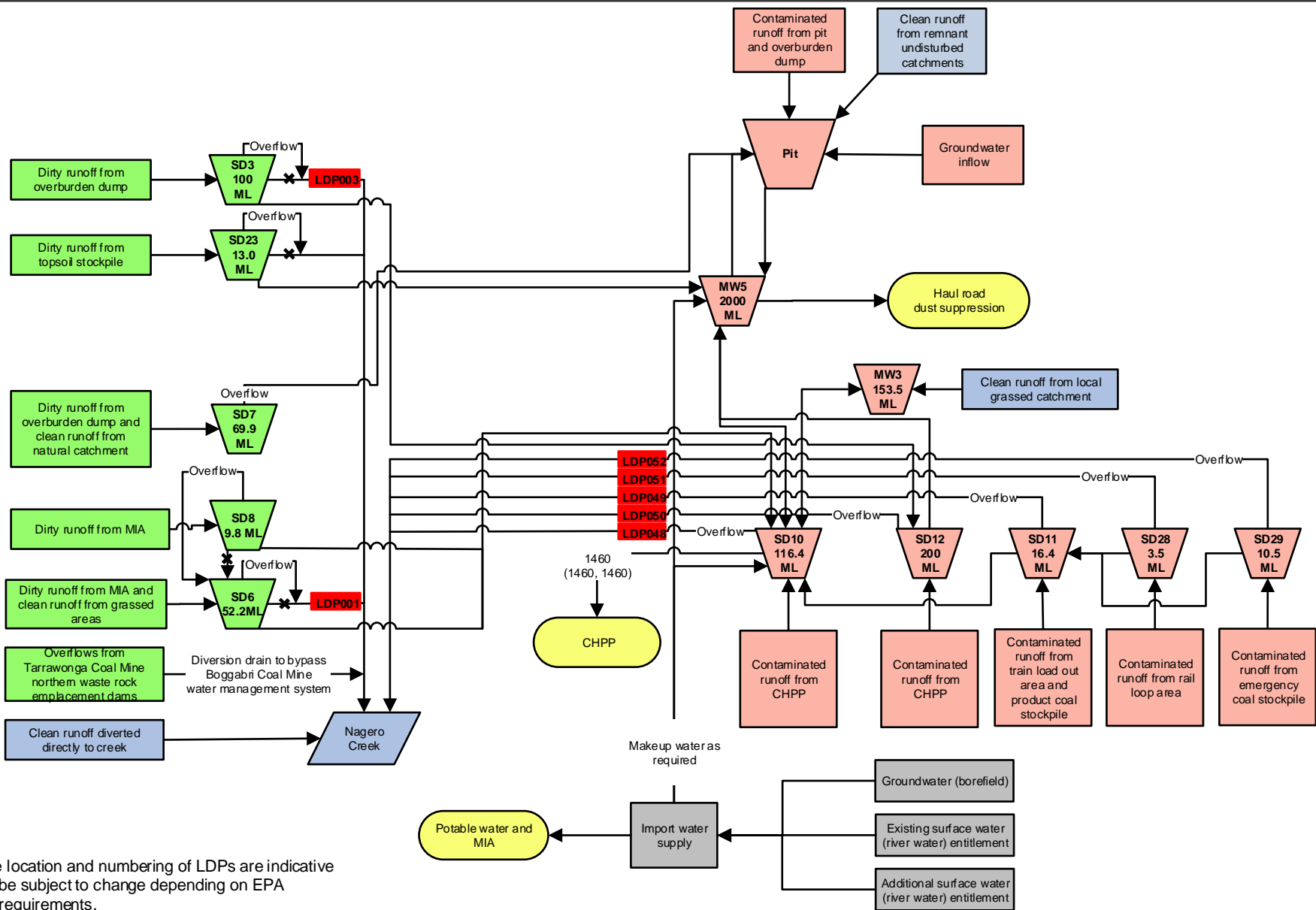

Note: The location and numbering of LDPs are indicative and may be subject to change depending on EPA licensing requirements.

LEGEND	
	Surface Water Transfer
	Storage
	Manually operated valve
	Median (ML/year) 10 th , 90 th percentile
	Import water system
	Dirty water system
	Contaminated water system
	Clean water system
	Usage

© 2017. Whilst every care has been taken to prepare this figure, GHD make no representations or warranties about its accuracy, reliability, completeness or suitability for any particular purpose and cannot accept liability and responsibility of any kind (whether in contract, tort or otherwise) for any expenses, losses, damages and/or costs (including indirect or consequential damage) which are or may be incurred by any party as a result of the figure being inaccurate, incomplete or unsuitable in anyway and for any reason.

LOCATION	BCM
DRAWN	TT
CHECKED	AW
APPROVED	SG
SCALE	NTS

Boggabri Coal Operations Pty Ltd
 Boggabri Coal Mine
 Site Water Balance
 Water balance model schematic
 Indicative conditions (2018)

DATE	5 May 2017	Figure B-7
------	------------	------------

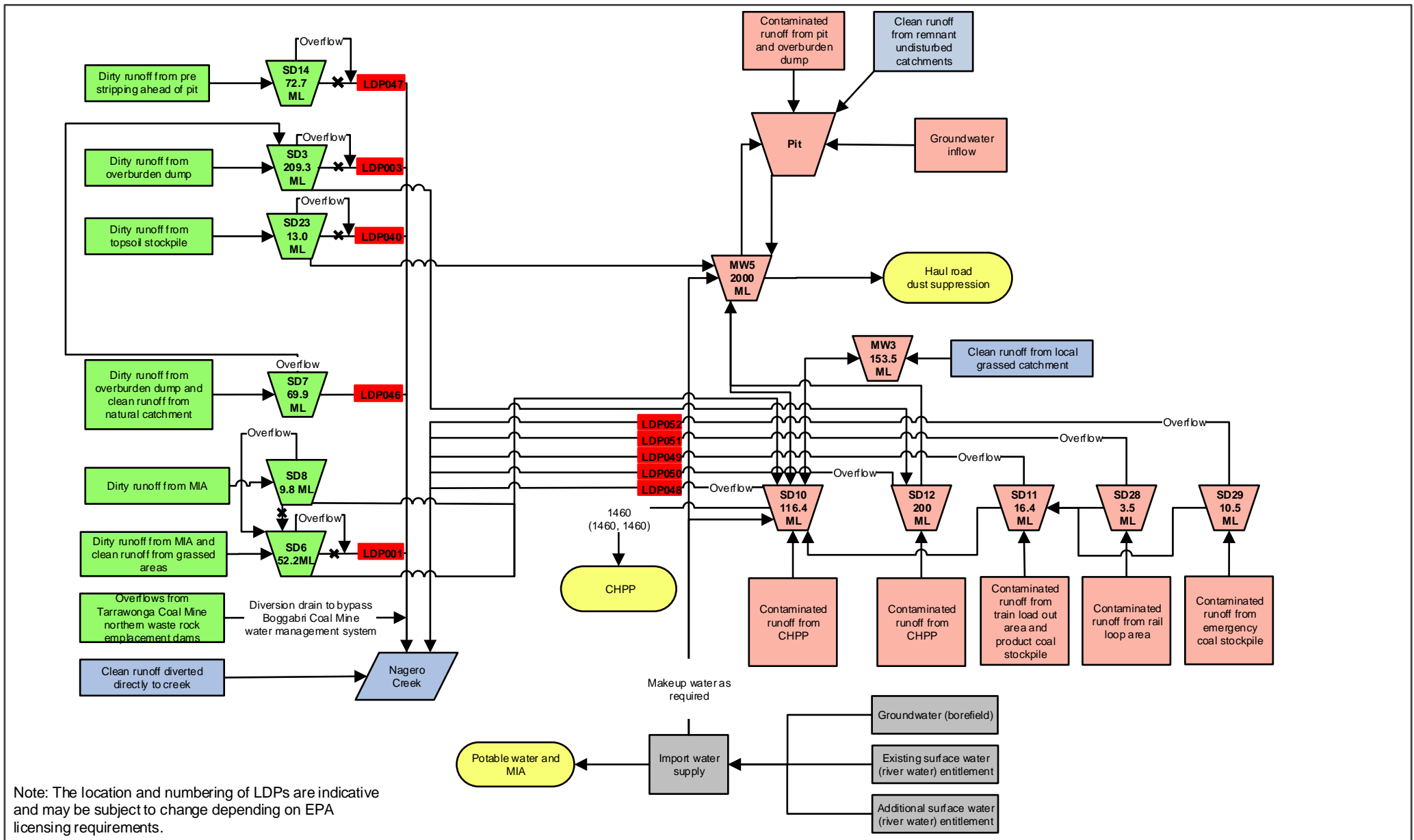

Note: The location and numbering of LDPs are indicative and may be subject to change depending on EPA licensing requirements.

	LEGEND	Import water system Dirty water system Contaminated water system Clean water system Usage	© 2017. Whilst every care has been taken to prepare this figure, GHD make no representations or warranties about its accuracy, reliability, completeness or suitability for any particular purpose and cannot accept liability and responsibility of any kind (whether in contract, tort or otherwise) for any expenses, losses, damages and/or costs (including indirect or consequential damage) which are or may be incurred by any party as a result of the figure being inaccurate, incomplete or unsuitable in anyway and for any reason.	LOCATION	BCM	Boggabri Coal Operations Pty Ltd Boggabri Coal Mine Site Water Balance Water balance model schematic Indicative conditions (2022)	
	Surface Water Transfer Storage Manually operated valve XX (XX, XX) Median (ML/year) 10 th , 90 th percentile	DRAWN TT CHECKED AW APPROVED SG SCALE NTS		DATE 5 May 2017	Figure B-8		

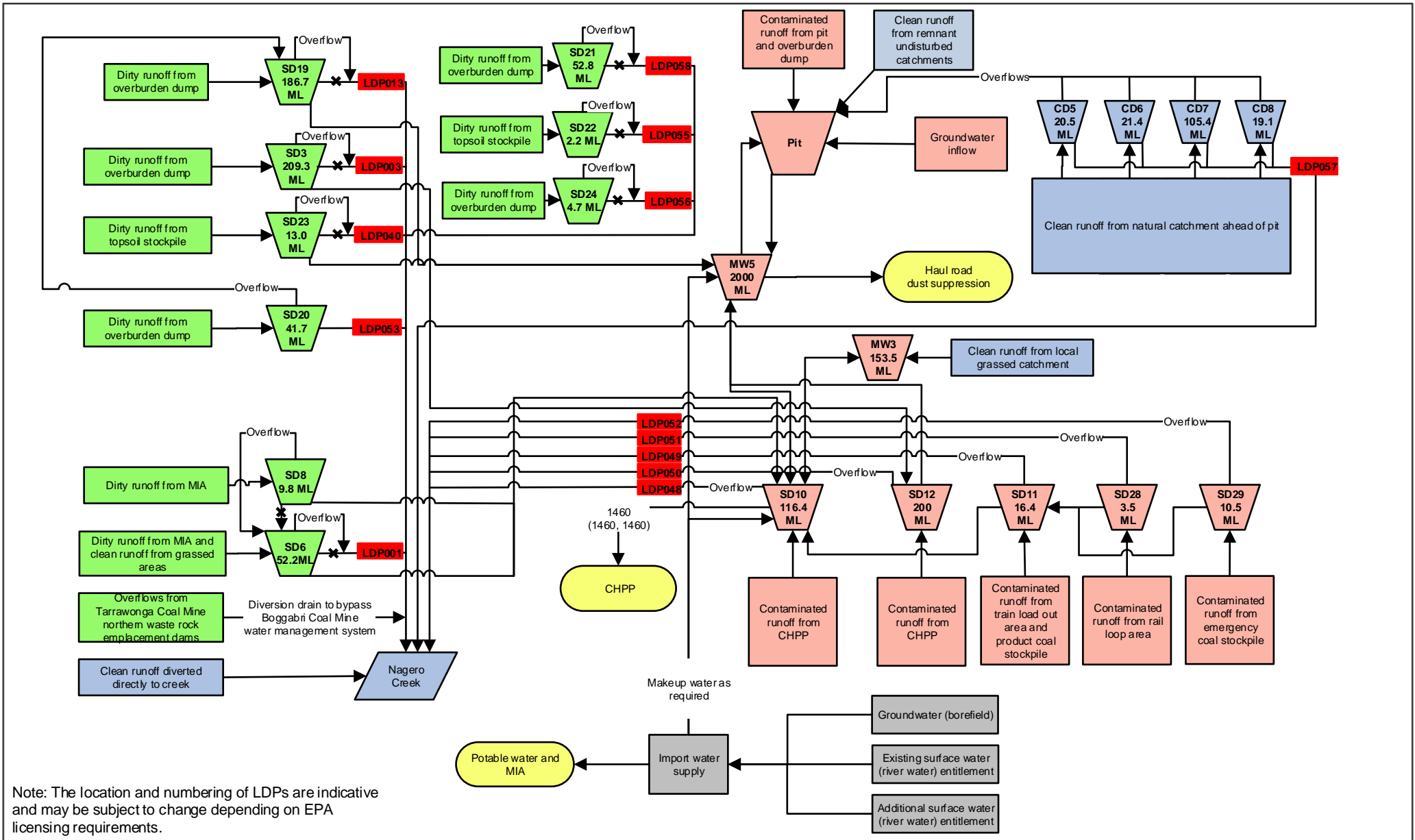

Note: The location and numbering of LDPs are indicative and may be subject to change depending on EPA licensing requirements.

LEGEND		Import water system	Dirty water system	Contaminated water system	Clean water system	Usage
	→ Surface Water Transfer					
	XX Median (ML/year)					
	(XX, XX) 10 th , 90 th percentile					

© 2017. While every care has been taken to prepare this figure, GHD make no representations or warranties about its accuracy, reliability, completeness or suitability for any particular purpose and cannot accept liability and responsibility of any kind (whether in contract, tort or otherwise) for any expenses, losses, damages and/or costs (including indirect or consequential damage) which are or may be incurred by any party as a result of the figure being inaccurate, incomplete or unsuitable in anyway and for any reason.	LOCATION	BCM	Boggabri Coal Operations Pty Ltd Boggabri Coal Mine Site Water Balance
	DRAWN	TT	
	CHECKED	AW	
	APPROVED	SG	
	SCALE	NTS	

Water balance model schematic Indicative conditions (2033)		
DATE	5 May 2017	
		Figure B-9

Appendix C

Summary of storages and discharge points

Table C 1 Summary of existing storages

Storage	Location / description	Stored water	Design criteria	Additional sediment allowance	Runoff coefficient	Catchment area (ha)	Required minimum capacity (ML)	Existing capacity (ML)	Notes
Dirty water dams									
SD3	Sediment dam located south-west of spoil dump	Dirty runoff from partially rehabilitated spoil dump	90 th %ile 5 day	50%	0.4 to 0.75	139.8	60.5	102.3	Existing capacity of 102.3 ML exceeds required capacity.
SD6	Sediment dam located downstream of MIA (referred to as Nagero Dam)	Runoff from grassed areas near MIA, and overflows from SD8	90 th %ile 5 day	50%	0.4 to 0.75	63.5	14.6	52.2	Existing capacity of 52.2 ML exceeds required capacity.
SD7	Sediment dam located in eastern spoil dump	Dirty runoff from spoil dump and clean runoff from undisturbed catchment	90 th %ile 5 day	50%	0.4 to 0.75	158.9	45.8	69.9	Existing capacity of 69.9 ML exceeds required capacity. Elevation of catchment does not allow return to environment.
SD8	Sediment dam located in MIA	Dirty runoff from MIA	90 th %ile 5 day	50%	0.75	13.0	5.6	9.8	Existing capacity of 9.8 ML exceeds required capacity.
SD23	Sediment dam located near topsoil stockpile	Dirty runoff from topsoil stockpile	90 th %ile 5 day	50%	0.75	20.0	8.7	9.5	Existing capacity of 9.5 ML exceeds required capacity.
Contaminated water dams									
SD10	Contaminated water dam located in CHPP	Contaminated runoff from product coal stockpile	100yr ARI 72hr	20%	0.85	27.1	70.7	116.4	Existing capacity of 116.4 ML exceeds required capacity. SD10 includes 'reuse zone' for water supply to CHPP.
SD11	Contaminated water dam located at rail loop	Contaminated runoff from rail loop	100yr ARI 72hr	20%	0.85	3.8	10.0	16.4	Existing capacity of 16.4 ML exceeds required capacity.

Storage	Location / description	Stored water	Design criteria	Additional sediment allowance	Runoff coefficient	Catchment area (ha)	Required minimum capacity (ML)	Existing capacity (ML)	Notes
SD12	Contaminated water dam located in CHPP	Contaminated runoff from ROM coal stockpile	100yr ARI 72hr	20%	0.85	63.8	165.7	206.6	Existing capacity of 206.6 ML exceeds required capacity.
SD28	Contaminated water dam located in CHPP	Contaminated runoff from rail loop area	100yr ARI 72hr	20%	0.85	1.0	2.6	3.5	Existing capacity of 3.5 ML exceeds required capacity.
SD29	Contaminated water dam located in CHPP	Contaminated runoff from emergency coal stockpile	100yr ARI 72hr	20%	0.85	4.0	10.4	10.5	Existing capacity of 10.5 ML exceeds required capacity.
MW2	Mine water dam located north-west of mining void (turkey's nest dam)	Contaminated water pumped from pit	100yr ARI 72hr	0%	1.0	3.8	9.7	175.8	Freeboard of 9.7 ML is maintained
MW3	Mine water dam located south of MIA	Surplus contaminated water pumped from SD10 and clean runoff from small grassed catchment	100yr ARI 72hr	0%	0.40	22.0	22.5	153.5	Freeboard of 22.5 ML is maintained
Pit	In-pit storage during wet periods	Contaminated runoff and groundwater make captured in the mining void sumps							Surplus contaminated water stored in-pit when capacity of Strip #9 and MWDs reached
Strip #9	Extra mine water storage for earlier surplus years	Surplus mine water from pit and from MW2 and MW5		0%	1.0	22.24	56.7	3426	Freeboard of 56.7 ML is maintained. Surplus contaminated water stored in Strip #9 when capacity of MWDs reached

Table C 2 Summary of existing discharge points

EPL identification number	Discharge type	Storage	Location / description	Stored water
Point 2	Discharge water quality monitoring and Wet weather discharge	SD3	Sediment dam located south-west of spoil dump	Dirty runoff from partially rehabilitated spoil dump
Point 1	Discharge water quality monitoring and Wet weather discharge	SD6	Sediment dam located downstream of MIA (Nagero Dam)	Runoff from grassed areas near MIA, and overflows from SD8
Point 4	Discharge water quality monitoring and Wet weather discharge	SD4	Sediment dam located downstream of train load out area west of BCM	Runoff from train load out area

Table C 3 Summary of proposed 2018 storages

Storage	Location / description	Stored water	Design criteria	Additional sediment allowance	Runoff coefficient	Catchment area (ha)	Required minimum capacity (ML)	Proposed capacity (ML)	Notes
Dirty water dams									
SD3	Sediment dam located south-west of spoil dump	Dirty runoff from partially rehabilitated spoil dump	90 th %ile 5 day	50%	0.4 to 0.75	213.2	92.1	100.0	
SD6	Sediment dam located downstream of MIA (referred to as Nagero Dam)	Runoff from grassed areas near MIA, and overflows from SD8	90 th %ile 5 day	50%	0.4 to 0.75	63.5	14.6	52.2	
SD7	Sediment dam located in eastern spoil dump	Dirty runoff from spoil dump and clean runoff from undisturbed catchment	90 th %ile 5 day	50%	0.4 to 0.75	229.1	64.4	69.9	SD7 water is harvested as elevation of catchment does not allow for return to environment. SD7 overflows to pit in 2018.
SD8	Sediment dam located in MIA	Dirty runoff from MIA	90 th %ile 5 day	50%	0.75	13.0	5.6	9.8	
SD23	Sediment dam located near topsoil stockpile	Dirty runoff from topsoil stockpile	90 th %ile 5 day	50%	0.75	20.0	8.7	9.5	
Contaminated water dams									
SD10	Contaminated water dam located in CHPP	Contaminated runoff from product coal stockpile	100 yr ARI 72 hr + 'reuse zone'	20%	0.85	27.1	70.7	116.4	
SD11	Contaminated water dam located at rail loop	Contaminated runoff from rail loop	100yr ARI 72hr	20%	0.85	3.8	10.0	16.4	

Storage	Location / description	Stored water	Design criteria	Additional sediment allowance	Runoff coefficient	Catchment area (ha)	Required minimum capacity (ML)	Proposed capacity (ML)	Notes
SD12	Contaminated water dam located in CHPP	Contaminated runoff from ROM coal stockpile	100yr ARI 72hr	20%	0.85	52.6	136.6	206.6	
SD28	Contaminated water dam located in CHPP	Contaminated runoff from rail loop area	100yr ARI 72hr	20%	0.85	1.0	2.6	3.5	
SD29	Contaminated water dam located in CHPP	Contaminated runoff from emergency coal stockpile	100yr ARI 72hr	20%	0.85	4.0	10.4	10.5	
MW3	Mine water dam located south of MIA	Surplus contaminated water pumped from SD10 and clean runoff from small grassed catchment	100yr ARI 72hr	0%	1.0 (Turkey's nest)	22.0	22.5	153.5	Freeboard of 22.5 ML will be maintained
MW5	Mine water dam (turkey's nest dam)	Contaminated water pumped from pit	100yr ARI 72hr	0%	1.0 (Turkey's nest)	15.2	38.8	2000.0	Freeboard of 38.8 ML will be maintained
In-pit	In-pit storage during wet periods	Contaminated runoff and groundwater make captured in the mining void sumps	Water balance	0%	-	-	-	-	Surplus contaminated water stored in-pit when capacity of MWDs reached

Table C 4 Summary of proposed 2018 discharge points

EPL identification number	Discharge type	Storage	Location / description	Stored water
Point 3	Discharge water quality monitoring and Wet weather discharge	SD3	Sediment dam located south-west of spoil dump	Dirty runoff from partially rehabilitated spoil dump
Point 1	Discharge water quality monitoring and Wet weather discharge	SD6	Sediment dam located downstream of MIA (Nagero Dam)	Runoff from grassed areas near MIA, and overflows from SD8
Point 4	Discharge water quality monitoring and Wet weather discharge	SD4	Sediment dam located downstream of train load out area west of BCM	Runoff from train load out area

Table C 5 Summary of proposed 2022 storages

Storage	Location / description	Stored water	Design criteria	Additional sediment allowance	Runoff coefficient	Catchment area (ha)	Required minimum capacity (ML)	Proposed capacity (ML)	Notes
Dirty water dams									
SD3	Sediment dam located south-west of spoil dump	Dirty runoff from partially rehabilitated spoil dump, and overflows from SD7	90 th %ile 5 day	50%	0.4 to 0.75	641.5	209.3	209.3	Upgrade from 100 ML to 209 ML required to cater for expanding spoil catchment (as SD13 is no longer proposed). Alternatively, if SD3 remains at 100 ML, a new sediment dam SD13 is required.
SD6	Sediment dam located downstream of MIA (referred to as Nagero Dam)	Runoff from grassed areas near MIA, and overflows from SD8	90 th %ile 5 day	50%	0.4 to 0.75	63.5	14.6	52.2	
SD7	Sediment dam located in eastern spoil dump	Dirty runoff from spoil dump and clean runoff from undisturbed catchment	90 th %ile 5 day	50%	0.4 to 0.75	247.0	57.7	69.9	SD7 water released to environment following settling of suspended solids (assuming that the EPL discharge criteria is met)
SD8	Sediment dam located in MIA	Dirty runoff from MIA	90 th %ile 5 day	50%	0.75	13.0	5.6	9.8	
SD14	Sediment dam located in pre-strip	Dirty runoff from cleared area ahead of mining	90 th %ile 5 day	50%	0.4	313.7	72.7	72.7	New dam
SD23	Sediment dam located near topsoil stockpile	Dirty runoff from topsoil stockpile	90 th %ile 5 day	50%	0.75	20.0	8.7	9.5	
Contaminated water dams									
SD10	Contaminated water dam located in CHPP	Contaminated runoff from product coal stockpile	100 yr ARI 72 hr + 'reuse zone'	20%	0.85	27.1	70.7	116.4	



Storage	Location / description	Stored water	Design criteria	Additional sediment allowance	Runoff coefficient	Catchment area (ha)	Required minimum capacity (ML)	Proposed capacity (ML)	Notes
SD11	Contaminated water dam located at rail loop	Contaminated runoff from rail loop	100yr ARI 72hr	20%	0.85	3.8	10.0	16.4	
SD12	Contaminated water dam located in CHPP	Contaminated runoff from ROM coal stockpile	100yr ARI 72hr	20%	0.85	52.6	136.6	206.6	
SD28	Contaminated water dam located in CHPP	Contaminated runoff from rail loop area	100yr ARI 72hr	20%	0.85	1.0	2.6	3.5	
SD29	Contaminated water dam located in CHPP	Contaminated runoff from emergency coal stockpile	100yr ARI 72hr	20%	0.85	4.0	10.4	10.5	
MW3	Mine water dam located south of MIA	Surplus contaminated water pumped from SD10 and clean runoff from small grassed catchment	100yr ARI 72hr	0%	1.0 (Turkey's nest)	22.0	22.5	153.5	Freeboard of 22.5 ML will be maintained
MW5	Mine water dam (turkey's nest dam)	Contaminated water pumped from pit	100yr ARI 72hr	0%	1.0 (Turkey's nest)	15.2	38.8	2000.0	Freeboard of 38.8 ML will be maintained
In-pit	In-pit storage during wet periods	Contaminated runoff and groundwater make captured in the mining void sumps	Water balance	0%	-	-	Predicted maximum volume stored in pit 1120 ML	-	Surplus contaminated water stored in-pit when capacity of MWDs reached

Table C 6 Summary of proposed 2022 discharge points

EPL identification number	Discharge type	Storage	Location / description	Stored water
Point 2	Discharge water quality monitoring and Wet weather discharge	SD3	Sediment dam located south-west of spoil dump	Runoff from rehabilitated spoil dump and overflows from SD7
Point 1	Discharge water quality monitoring and Wet weather discharge	SD6	Sediment dam located downstream of MIA (Nagero Dam)	Runoff from grassed areas near MIA, and overflows from SD8
Point 40	Discharge water quality monitoring and Wet weather discharge	SD23	Sediment dam located near topsoil stockpile	Dirty runoff from topsoil stockpile
TBA	Discharge water quality monitoring	SD7	Sediment dam located in eastern spoil dump	Dirty runoff from spoil dump and clean runoff from undisturbed catchment
TBA	Discharge water quality monitoring and Wet weather discharge	SD14	Sediment dam located in pre-strip	Dirty runoff from cleared area ahead of mining
TBA	Wet weather discharge (>100yr ARI 72hr design event)	SD10	Contaminated water dam located in CHPP	Contaminated runoff from product coal stockpile
TBA	Wet weather discharge (>100yr ARI 72hr design event)	SD11	Contaminated water dam located at rail loop	Catchment is from Train Load Out (TLO) area and the product stockpile on the southern side of the rail loop
TBA	Wet weather discharge (>100yr ARI 72hr design event)	SD12	Contaminated water dam located in CHPP	Contaminated runoff from ROM coal stockpile
TBA	Wet weather discharge (>100yr ARI 72hr design event)	SD28	Contaminated water dam located in CHPP	Contaminated runoff from rail loop area
TBA	Wet weather discharge (>100yr ARI 72hr design event)	SD29	Contaminated water dam located in CHPP	Contaminated runoff from emergency coal stockpile

Table C 7 Summary of proposed 2033 storages

Storage	Location / description	Stored water	Design criteria	Additional sediment allowance	Runoff coefficient	Catchment area (ha)	Required minimum capacity (ML)	Proposed capacity (ML)	Notes
Dirty water dams									
SD3	Sediment dam located south-west of spoil dump	Dirty runoff from partially rehabilitated spoil dump	90 th %ile 5 day	50%	0.4 to 0.75	197.7	49.6	209.3	Sized for 2022 catchment
SD6	Sediment dam located downstream of MIA (referred to as Nagero Dam)	Runoff from grassed areas near MIA, and overflows from SD8	90 th %ile 5 day	50%	0.4 to 0.75	63.5	14.6	52.2	
SD8	Sediment dam located in MIA	Dirty runoff from MIA	90 th %ile 5 day	50%	0.75	13.0	5.6	9.8	
SD19	Sediment dam located in spoil dump	Runoff from recently rehabilitated spoil dump and overflows from SD20	90 th %ile 5 day	50%	0.75	415.3	179.9	179.9	New dam. Sized using 0.75 runoff coefficient for recently rehabilitated areas
SD20	Sediment dam located in spoil dump	Dirty runoff from spoil dump	90 th %ile 5 day	50%	0.75	100.9	41.8	41.8	New dam
SD21	Sediment dam located in spoil dump	Dirty runoff from spoil dump	90 th %ile 5 day	50%	0.75	127.5	55.6	55.6	New dam
SD22	Sediment dam located in spoil dump	Dirty runoff from spoil dump	90 th %ile 5 day	50%	0.75	5.5	2.4	2.4	New dam
SD23	Sediment dam located near topsoil stockpile	Dirty runoff from topsoil stockpile	90 th %ile 5 day	50%	0.75	20.0	8.7	9.5	



Storage	Location / description	Stored water	Design criteria	Additional sediment allowance	Runoff coefficient	Catchment area (ha)	Required minimum capacity (ML)	Proposed capacity (ML)	Notes
SD24	Sediment dam located in spoil dump	Dirty runoff from spoil dump	90 th %ile 5 day	50%	0.75	16.9	7.3	7.3	New dam
Contaminated water dams									
SD10	Contaminated water dam located in CHPP	Contaminated runoff from product coal stockpile	100 yr ARI 72 hr + 'reuse zone'	20%	0.85	27.1	70.7	116.4	
SD11	Contaminated water dam located at rail loop	Contaminated runoff from rail loop	100yr ARI 72hr	20%	0.85	3.8	10.0	16.4	
SD12	Contaminated water dam located in CHPP	Contaminated runoff from ROM coal stockpile	100yr ARI 72hr	20%	0.85	52.6	136.6	206.6	
SD28	Contaminated water dam located in CHPP	Contaminated runoff from rail loop area	100yr ARI 72hr	20%	0.85	1.0	2.6	3.5	
SD29	Contaminated water dam located in CHPP	Contaminated runoff from emergency coal stockpile	100yr ARI 72hr	20%	0.85	4.0	10.4	10.5	
MW3	Mine water dam located south of MIA	Surplus contaminated water pumped from SD10 and clean runoff from small grassed catchment	100yr ARI 72hr	0%	1.0 (Turkey's nest)	22.0	22.5	153.5	Freeboard of 22.5 ML will be maintained
MW5	Mine water dam (turkey's nest dam)	Contaminated water pumped from pit	100yr ARI 72hr	0%	1.0 (Turkey's nest)	15.2	38.8	2000.0	Freeboard of 38.8 ML will be maintained



Storage	Location / description	Stored water	Design criteria	Additional sediment allowance	Runoff coefficient	Catchment area (ha)	Required minimum capacity (ML)	Proposed capacity (ML)	Notes
In-pit	In-pit storage during wet periods	Contaminated runoff and groundwater make captured in the mining void sumps	Water balance	0%	-	-	Predicted maximum volume stored in pit 1310 ML	-	Surplus contaminated water stored in-pit when capacity of MWDs reached
Clean water dams									
CD5	Highwall dam located ahead of pit	Undisturbed catchment runoff	100yr ARI 72hr	0%	0.4	19.9	20.5	20.5	New dam
CD6	Highwall dam located ahead of pit	Undisturbed catchment runoff	100yr ARI 72hr	0%	0.4	20.7	21.4	21.4	New dam
CD7	Highwall dam located ahead of pit	Undisturbed catchment runoff	100yr ARI 72hr	0%	0.4	102.9	105.4	105.4	New dam
CD8	Highwall dam located ahead of pit	Undisturbed catchment runoff	100yr ARI 72hr	0%	0.4	18.3	19.1	19.1	New dam

Table C 8 Summary of proposed 2033 discharge points

EPL identification number	Discharge type	Storage	Location / description	Stored water
Point 2	Discharge water quality monitoring and Wet weather discharge	SD3	Sediment dam located south-west of spoil dump	Runoff from rehabilitated spoil dump
Point 1	Discharge water quality monitoring and Wet weather discharge	SD6	Sediment dam located downstream of MIA (Nagero Dam)	Runoff from grassed areas near MIA, and overflows from SD8
Point 4	Discharge water quality monitoring and Wet weather discharge	SD4	Sediment dam located downstream of train load out area west of BCM	Runoff from train load out area
TBC	Discharge water quality monitoring. Wet weather discharge.	SD8	Sediment dam located in MIA	Dirty runoff from MIA
TBC	Discharge water quality monitoring. Wet weather discharge.	SD20	Sediment dam located in spoil dump	Dirty runoff from spoil dump
TBC	Discharge water quality monitoring. Wet weather discharge.	SD19	Sediment dam located in spoil dump	Dirty runoff from spoil dump
TBC	Discharge water quality monitoring. Wet weather discharge.	SD22	Sediment dam located in spoil dump	Dirty runoff from spoil dump
TBC	Discharge water quality monitoring. Wet weather discharge.	SD24	Sediment dam located in spoil dump	Dirty runoff from spoil dump
TBC	Discharge to waters	-	Outlet from clean water dams	-

Appendix D

Water management system stage-storage relationships

Table D-1 MW2 stage-storage relationship (existing)

Level (m AHD)	Area (m ²)	Volume (m ³)	Level (m AHD)	Area (m ²)	Volume (m ³)
279.8	49.042	1.562	284.6	32748.67	68031.35
279.9	97.532	8.873	284.7	32974.38	71244.95
280	155.495	21.301	284.8	33191.01	74479.02
280.1	240.064	40.558	284.9	33319.45	77726.95
280.2	314.951	68.145	285	33433.76	80983.26
280.3	382.472	102.512	285.1	33547.47	84247.72
280.4	447.984	143.313	285.2	33660.58	87520.26
280.5	512.777	190.44	285.3	33773.09	90800.84
280.6	596.572	244.183	285.4	33884.99	94089.37
280.7	714.557	308.446	285.5	33996.29	97385.8
280.8	824.031	384.208	285.6	34106.99	100690.1
280.9	953.826	469.709	285.7	34217.08	104002.1
281	1521.506	589.331	285.8	34326.58	107321.8
281.1	2021.335	763.473	285.9	34435.47	110649.1
281.2	2526.516	987.746	286	34543.76	113984.1
281.3	3064.19	1262.522	286.1	34651.45	117326.5
281.4	3639.896	1591.039	286.2	34758.53	120676.3
281.5	4279.468	1984.034	286.3	34865.01	124033.5
281.6	5044.956	2442.781	286.4	34970.89	127398.1
281.7	5691.622	2972.336	286.5	35076.39	130769.8
281.8	6299.459	3563.109	286.6	35206.88	134149.7
281.9	7031.475	4217.783	286.7	35379.38	137541.6
282	7687.273	4945.028	286.8	35564.89	140948.5
282.1	8243.562	5730.386	286.9	35751.15	144370.9
282.2	8849.38	6571.075	287	35938.83	147808.8
282.3	9766.201	7484.506	287.1	36123.04	151262.3
282.4	11586.72	8529.591	287.2	36294.49	154730.3
282.5	13691.36	9771.12	287.3	36454.73	158211.8
282.6	17622.04	11303.95	287.4	36618.07	161706.1
282.7	20294.43	13191.18	287.5	36787.39	165213.9
282.8	22763.67	15326.79	287.6	36988.58	168736.7
282.9	25053.48	17697.31	287.7	37240.17	172279.1
283	26406.67	20252.54	287.8	37515.36	175844.5
283.1	27139.94	22905.34			
283.2	27727.45	25617.37			
283.3	28274.48	28384.69			
283.4	28963.76	31210.88			
283.5	29545.87	34099.57			
283.6	30013.92	37038.84			
283.7	30359.94	40015.1			
283.8	30708.19	43022.87			
283.9	31077.74	46063.71			
284	31395.93	49136.47			
284.1	31643.57	52234.83			
284.2	31875.33	55353.91			
284.3	32128.47	58494.6			
284.4	32347.38	61655.76			
284.5	32550.46	64835.09			